

See discussions, stats, and author profiles for this publication at: <https://www.researchgate.net/publication/327135964>

Sol-gel processing of ordered MnO₂ structures toward enhanced O₂ reduction catalysis for air batteries

Poster · May 2018
DOI: 10.1146/annurev-chem-2018-0502

CITATIONS
0

5 authors, including:

 Marja Milosavljevic
Institute of Chemistry, Technology and Metallurgy, Belgrade, Serbia
24 PUBLICATIONS 47 CITATIONS
[SEE PROFILE](#)

 Srećko Stupić
RWTH Aachen University
103 PUBLICATIONS 1,014 CITATIONS
[SEE PROFILE](#)

Some of the authors of this publication are also working on these related projects:

 Sustainable Recycling Concept: Efficient Melting [View project](#)

 CORNET - LFUK2020 Sustainable Recovery of Rare Earth Elements (Mg,Dy,Pi) from spent NdFeB magnets [View project](#)

READ
69

 Jasmina Stojanović
Institute of Chemistry, Technology and Metallurgy, University of Belgrade
140 PUBLICATIONS 1,113 CITATIONS
[SEE PROFILE](#)

 Vladimir Pačić
Institute of Chemistry, Technology and Metallurgy, University of Belgrade
67 PUBLICATIONS 909 CITATIONS
[SEE PROFILE](#)

Sol-gel processing of ordered MnO_2 structures toward enhanced O_2 reduction catalysis for air batteries

Marija Mihailović¹, Jasmina Stevanović¹, Srećko Stopić², Vladimir Panić¹, Bernd Friedrich²

¹Institute of Chemistry, Technology and Metallurgy, University of Belgrade, Department of Electrochemistry, Njegoševa 12, 11000 Belgrade, Serbia

²Institut für Metallurgische Prozesstechnik und Metallrecycling, RWTH Aachen University, Intzestraße 3, 52056 Aachen, Deutschland

The catalysis of electrochemical oxygen reaction (ECOR), as an essential reaction occurring in energy conversion systems, such as fuel cells or metal–air batteries, is still to be improved. The improvement relates to the synthesis of the catalysts other than Pt onto which rather slow ECOR would take place with acceptable rate and stable activity and cyclability of the catalyst. Newest investigation revealed that composite oxides based on MnO_2 are of sufficient activity to replace Pt in ECOR. Ordered structures and hierarchical distribution of the oxide components, incorporated within other non-expensive and noble-metal-free elements are the main goals of the synthesis routes. The present work reports the synthesis of ordered MnO_2 -based structures by combined sol–gel (SG) processing and ultrasonic spray pyrolysis (USP): $\text{CeO}_2|\text{MnO}_2$ and $\text{LaSrCoO}_3|\text{MnO}_2$. These SG–USP materials are investigated for their ECOR activities in alkaline solution.

Metal-air batteries attracted much attention recently due to extremely high energy density compared to other rechargeable batteries. The high specific energy density is a result of the coupling of a reactive metal anode to an air electrode. Cathode must be able to sustain an ORR, as well as oxygen oxidation reaction if battery is rechargeable.

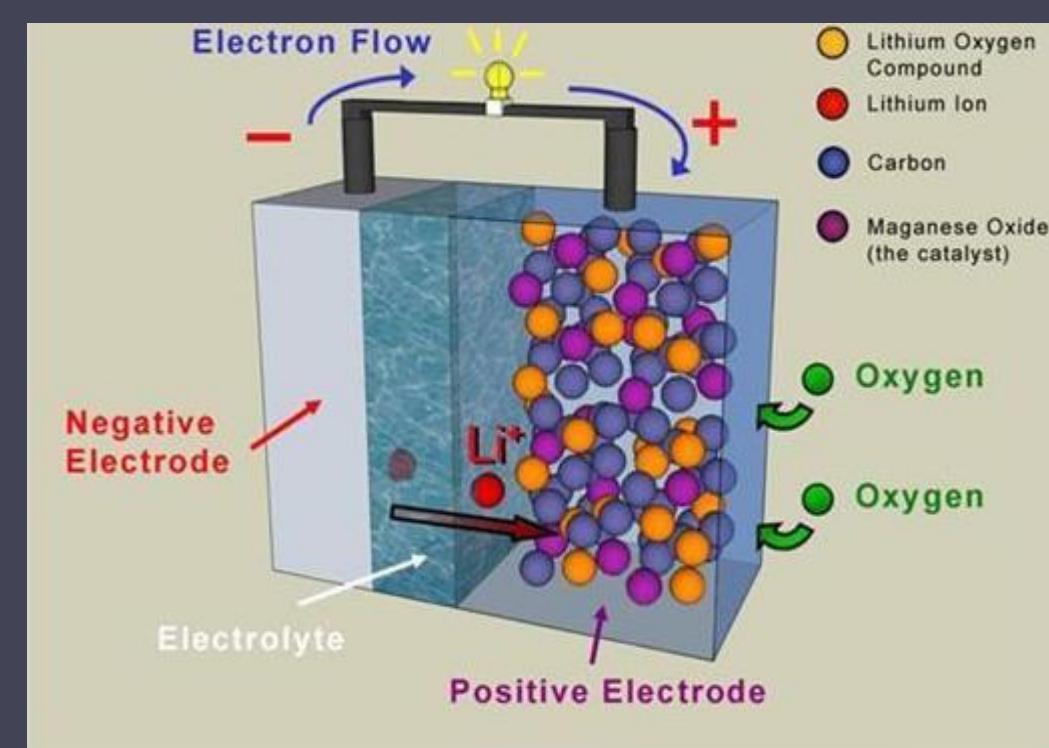

Fig.1 Metal-air battery (Li could also be Al, Zn etc.)

[<http://slideplayer.com/slide/3452993/>]

Fuel cells requires a continuous source of fuel and oxygen (usually from air) to sustain the operation.

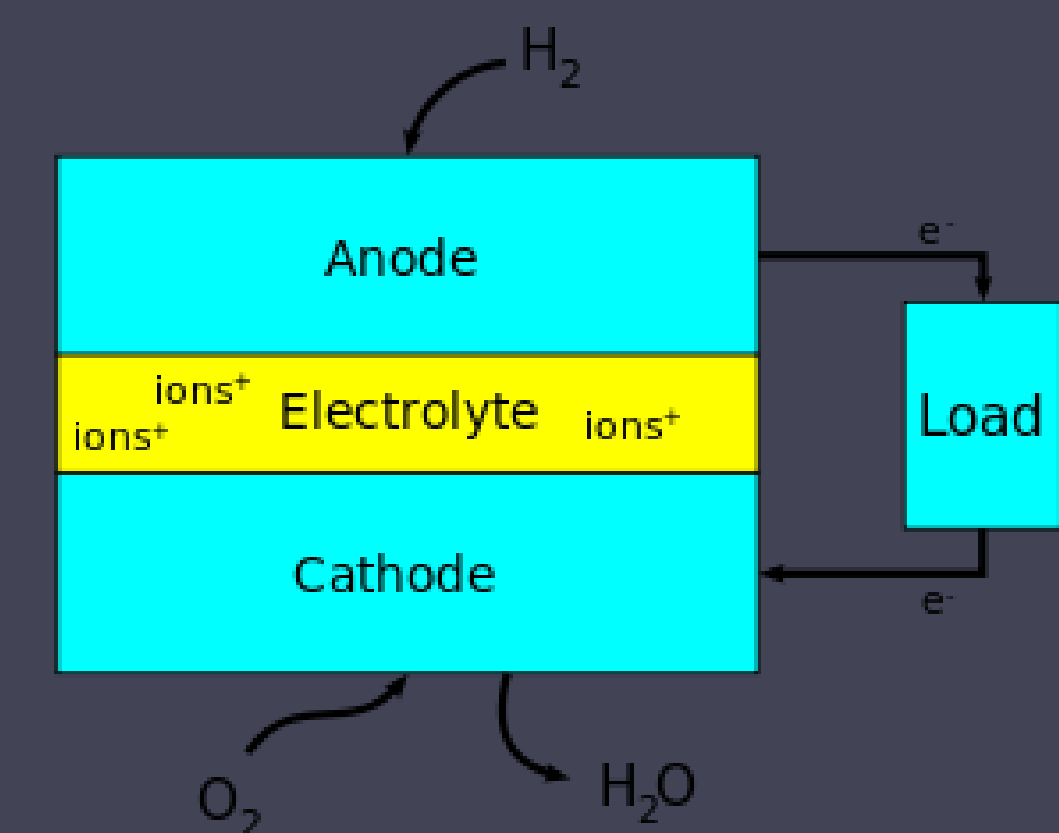
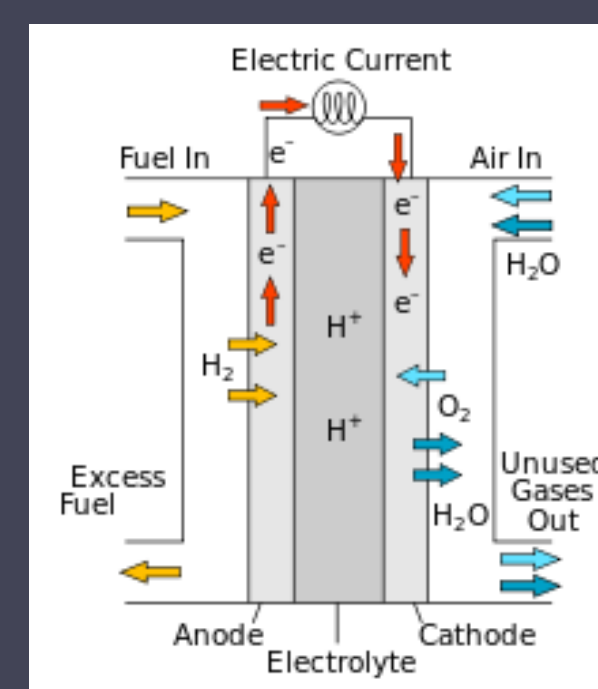

Fig.2 Block diagram of a fuel cell (H_2 could also be hydride, methanol, ethanol, formic acid etc.) [https://en.wikipedia.org/wiki/Fuel_cell]

EXPERIMENTAL

The MnO_2 sol was obtained through a procedure in which the aqueous solution of KMnO_4 reacted with of methanol after continuous agitation at magnetic stirrer. The precipitate was rinsed with water and subjected to ultrafiltration in several stages in order to obtain homogeneous dispersion. Ultrafiltration was carried out using Amicon Stirred Cell at the pressure of 3.5 bar at the magnetic stirring rate of 300 rpm, while the dispersion had pH value of 8.4. The solid phase spontaneously split into two phases: the gel was precipitated at the membrane (**magnetically unstable MnO_2 phase**), stable colloidal dispersion above membrane (**magnetically stable MnO_2 phase**). Both, the stable and unstable phase were separately sampled and dried at 120°C for 9 hours.

$\text{MnO}_2@ \text{CeO}_2$ was synthesized to reach the nominal composition of 1:1 oxide mass ratio. The precursor for CeO_2 was $\text{Ce}(\text{SO}_4)_2 \cdot 4\text{H}_2\text{O}$, which simultaneously hydrolyzed in presence of CH_3OH and KMnO_4 water solution. Upon change of the colour of a mixture from yellow-purple to dark brown, the precipitate was rinsed with $\text{C}_2\text{H}_5\text{OH}$ and dried afterwards at 110°C for 24 hours.

Thin layers of stable and unstable MnO_2 , as well as $\text{MnO}_2@ \text{CeO}_2$, applied to glassy carbon (GC) working electrode, were electrochemically examined in O_2 saturated 0.1M KOH by CV and LSV techniques.

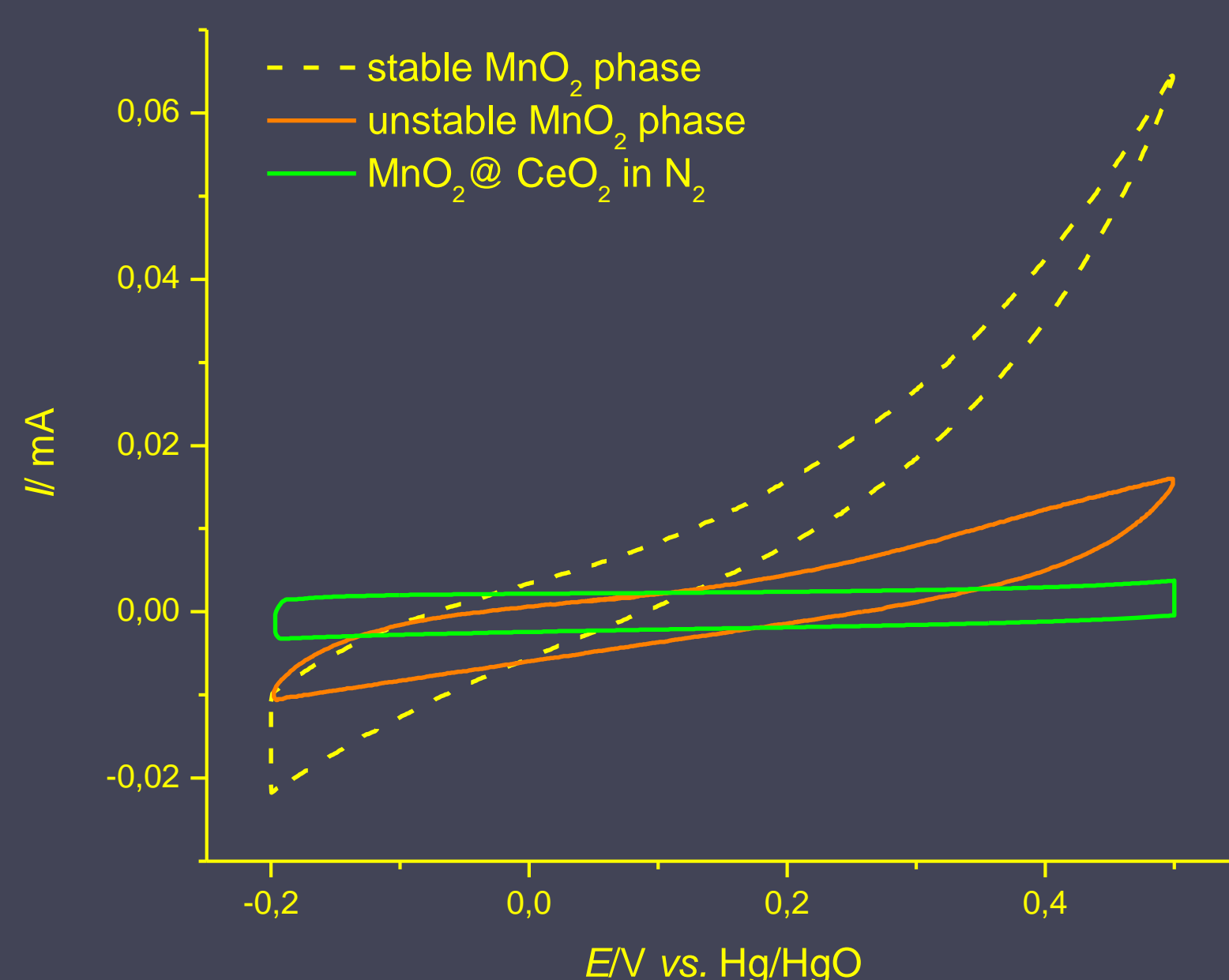

Fig. 3: CV responses in deaerated 0.1M KOH indicate similar low-current featureless shapes for all samples. There is a strong indication of different conductivities since the CVs are of different inclination. CeO_2 considerably improves the MnO_2 conductivity, especially with respect to magnetically insensitive sample.

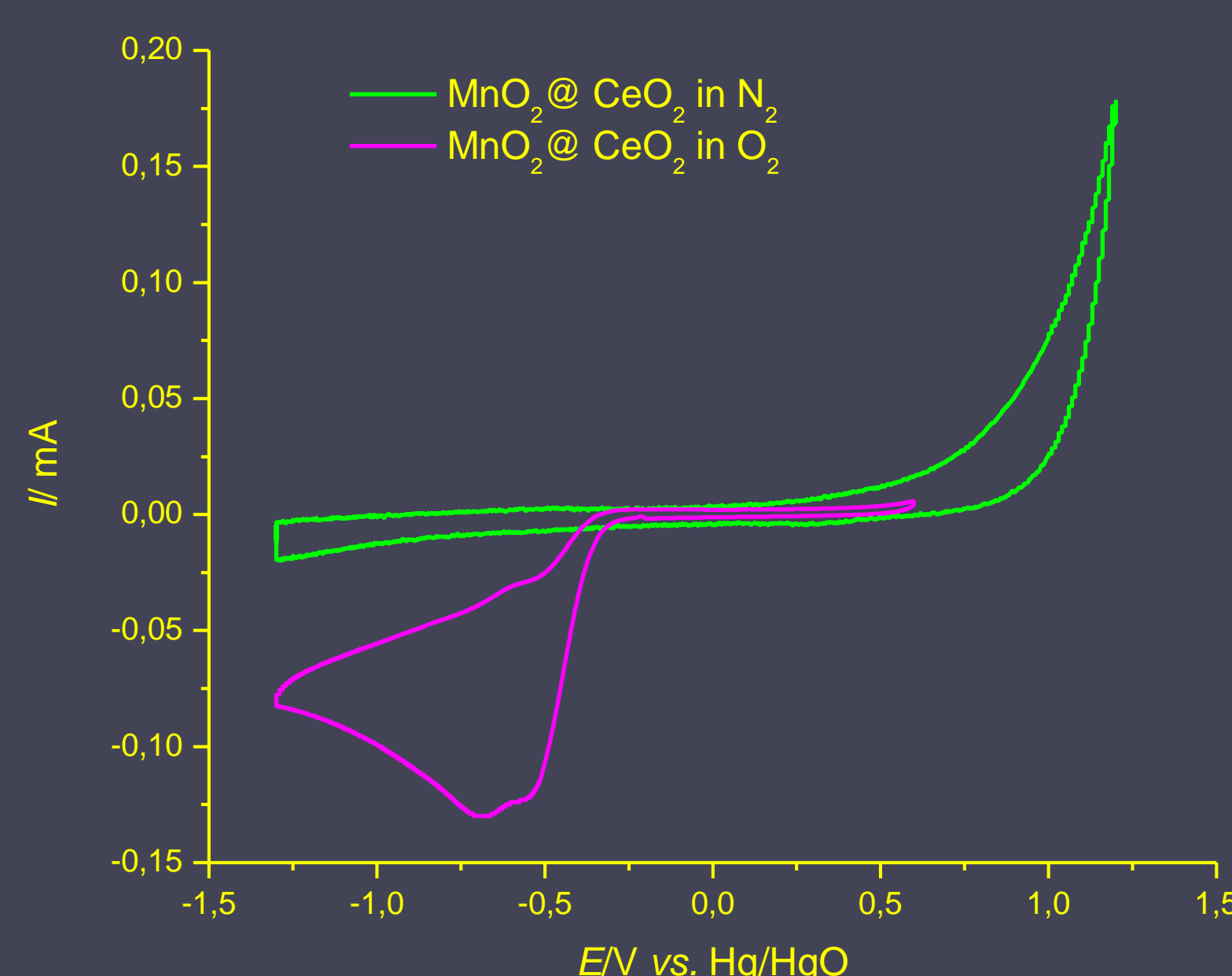

Fig. 4: $\text{MnO}_2@ \text{CeO}_2$ shows remarkable activity toward ORR in alkaline solution, with a potential region similar to other electrocatalysts known upon ORR activity.

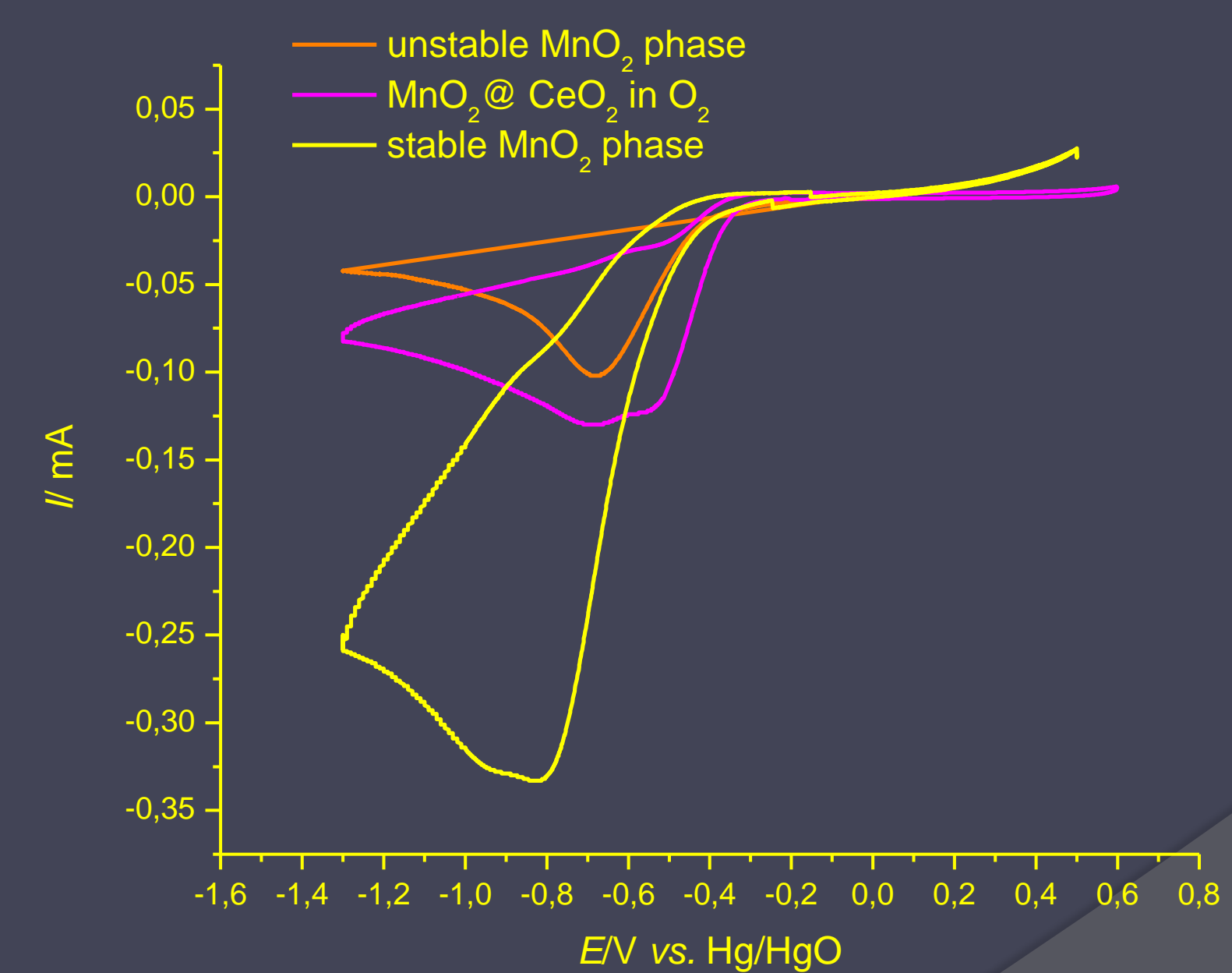

Fig.5: Although the MnO_2 content in a $\text{MnO}_2@ \text{CeO}_2$ thin layer is a half of that in MnO_2 pure layers, ORR currents are higher with respect to magnetically unstable MnO_2 phase. The reaction starts at the potential of about 100 mV more positive values than in the case of pure MnO_2 . The ORR activity appears considerably affected by magnetic state of MnO_2 .