An Estimation of PFC Emission by Rare Earth Electrolysis

Hanno Vogel and Bernd Friedrich

Abstract

Currently there is no inventory of the emission and no documentation of the smelting capacity, technology level and location of rare earth smelters. So far, the emission from rare earth smelting is not taken into account in climate change research and policy makers. This work creates an estimate of the PFC emission by rare earth electrolysis. First, the annual rare earth metal production by electrolysis is estimated in the range of up to 35,000 t per year. The process technology review and theory of PFC formation suggest a high amount of PFC emission. Laboratory measurements of CF_4 and C_2F_6 in the off-gas of a neodymium electrolysis confirm the possibility of continuous PFC emission with about 74 g CF_4 and 12 g C_2F_6 per kilogram RE metal. Combined with the production estimate, an annual PFC emission by RE electrolysis of about 25,000,000 t $\text{CO}_2\text{-eq}$ is calculated. Based on the consumption of raw material, a medium-emission scenario with up to 10,000,000 t $\text{CO}_2\text{-eq}$ is attained, with a mass of 30 g CF_4 and 3 g C_2F_6 per kilogram RE metal. This range of PFC emission highlights the importance of conducting industrial measurements and improving the electrolysis process to lower emissions. The regional distribution of PFC emission is derived by analyzing the light metal production quota of Chinese companies. In Baotou the majority of PFC is emitted, followed by the mining region in Sichuan. Southern China and the border region of Laos and Vietnam emit much less PFC.

Keywords

PFC emission • Rare earth • Neodymium electrolysis
 CF_4 • C_2F_6

Introduction

Perfluorocarbons (PFC) are among the most significant greenhouse gases emitted by the industry. Rare earth (RE) smelting was regarded as a negligible source of PFC, due to the small production quantity of about 30,000 t per annum. Because of the different technology of RE smelting compared to the similar aluminum electrolysis, there is the possibility of a high specific PFC emission making the industry an important contributor [1]. So far, just one publication of industrial PFC measurement by RE electrolysis is available [19]. By estimating the amount of metal production per year and combining it with specific PFC emission, three scenarios are proposed. Further, the regional distribution of PFC emission is estimated by comparing the mining area and output. This work aims to estimate the amount and distribution of PFC emission from RE smelting to initiate or enable further research and improvement of the RE electrolysis and PFC models.

Technology of Rare Earth Smelting

Often the term “rare earth metal” is used to refer to all kinds of compounds of the lanthanides including scandium and yttrium. Many applications require different rare earth compounds. However, the raw material and trading goods are usually the rare earth oxides (REO).

Only about half of the REO is converted to metal mainly for the use in permanent magnets. The strongest magnet alloy contains about 28% by mass neodymium. The magnets are used for efficient power generators in wind turbines and electric motors. About 10% of the neodymium can be

H. Vogel (✉)
TRIMET Aluminium SE, Aluminiumallee 1, 45356 Essen,
Germany
e-mail: hanno.vogel@trimet.de

B. Friedrich
RWTH Aachen University, IME Institute of Process Metallurgy
and Metal Recycling Intzestraße 3, Aachen, Germany

substituted by praseodymium. To increase the temperature stability the addition of up to 4% dysprosium is common. Rare earth metals are also used in the misch-metal alloy consisting of mainly La–Ce to produce flint stone and des-oxidation material [2].

Because of the highly ignoble character of rare earth elements, the reduction is more energy intensive than the reduction of aluminum oxide. The carbothermic reduction is practically not possible to conduct. The metallothermic reduction is possible with the affordable element calcium. Hence, calciothermic reduction is used to produce batch wise small quantities of the pure required RE metal like dysprosium. In industrial scale, samarium for the production of Sm–Co magnets is co-reduced with cobalt by calcium. The calciothermic reduction has no gaseous reaction product and is usually done in sealed chambers. There is no direct green-house gas emission by this process. Chloride electrolysis was used to produce Fe–RE alloys electrochemically. The required temperature for the smelting of pure RE metal makes the chloride system uneconomically [2].

The metals and alloys Nd, Nd–Pr, Fe–Dy, La, Ce and mischmetal are produced by an electrolytic reduction process of the RE oxide similar to the Hall–Héroult process for smelting aluminum, accompanied by the emission of the same perfluorocarbons (PFC) with a very strong green-house potential. In 1984, the first industrial neodymium oxide electrolysis was developed in China with about 2.5 kA current. The round cell with vertical electrode set-up has a diameter of about 1 m (Fig. 1). In 2000, the electrolysis was improved to run continuously with anode changes during production in a 4–6 kA cell. This technology is the most common one, with more than 100 factories in Baotou and southern China in 2005 [3, 4].

An electrolyte for the production of neodymium is composed of about 85% neodymium fluoride (NdF_3) and 15% by weight lithium fluoride (LiF). Nd_2O_3 is dissolved in the fluoride electrolyte. On a vertical tungsten cathode, the liquid neodymium is deposited at about 1050 °C. The heavy RE element dysprosium is too high melting to win it in pure form. Still it can be electrolytically won by using an iron cathode, which forms a low melting Dy–Fe alloy. The liquid metal or alloy drops in an inert crucible and is periodically tapped out of the cell. The ring shaped graphite anode surrounds the cathode vertically and reacts mainly with the oxygen containing ion to CO and CO_2 . The anode cathode distance is determined by the cell setup and cannot be adjusted by the anode position. The cell voltage cannot be used as a process control value, which is the essential control parameter within the similar aluminum electrolysis [3].

The small cell runs at high energy input of about 12 kWh per kilogram neodymium. The cell voltage is about 12 V with a current of about 2.5 kA and a current efficiency of about 70%. There are many issues to overcome and to

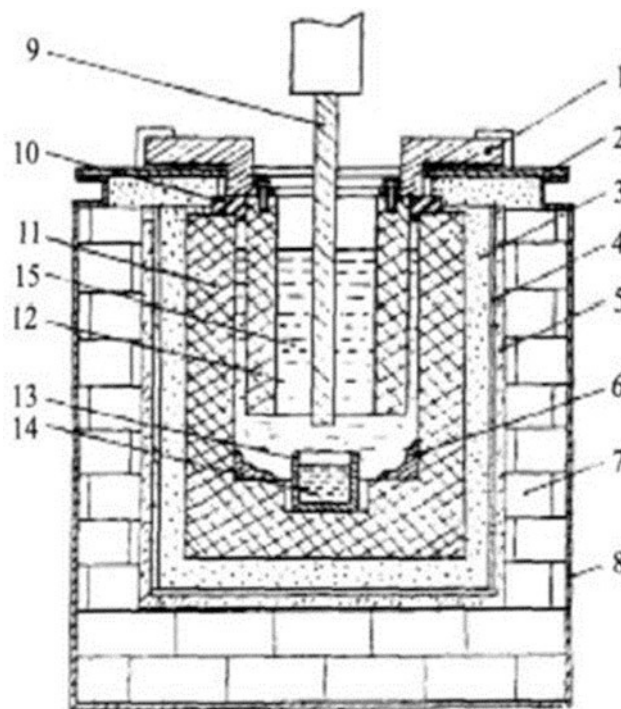

Fig. 1 Sketch of a 3 kA rare earth electrolysis cell [5], 1 Anode conductive plate. 2 Cover. 3 Thermal insulation layer. 4 Iron layer. 5 Asbestos fiber layer. 6 Electrolyte crust. 7 Insulating bricks. 8 Shell. 9 W cathode. 10 Corundum gasket. 11 Graphite crucible. 12 Graphite anode. 13 Mo crucible. 14 Liquid Nd metal. 15 Liquid electrolyte

improve this technology. The attempt to mimic the horizontal cell design of the aluminum electrolysis was not successful yet [3, 6].

The first scale-up of the cell was developed about 10 years later leading to an increase in current efficiency and improvement in energy consumption. So far, the oxide feeding is managed by hand and the metal is tapped with a titanium spoon manually. There is no publication of an automated process control with an oxide feeding system. Probably the big RE companies are developing the technology further to gain better quality in the product and lower costs. For small smelters the electrolysis remains manually operated by experience.

The voltage in combination with the anodic current density and oxide concentration in the electrolyte is crucial for the anodic reaction. At too high voltage and too low oxide concentration, fluorides are oxidized and the perfluorocarbons CF_4 along with C_2F_6 are formed. The reaction mechanism is similar to the aluminum electrolysis system. Laboratory experiments show, that the process of RE electrolysis in contrast to the aluminum electrolysis can run continuously with PFC emission. In the aluminum electrolysis with a low superheat and horizontal electrodes the anodes tend to passivate with the development of PFCs and the cell voltage rises. This event is easily detectable by the controller and operator

making it possible to take counter measures. This seems not to be the case within the RE smelting. The high temperature and high super heat result in an easy removal of the PFC gas bubbles from the anode. The high risk of anodic PFC formation and the low level of process automation leads to potentially high green-house gas emissions [7].

Estimate of the Annual Amount of Rare Earth Metal Production

Numbers for the world production of RE are based on oxides. Reliable data are hard to obtain, because a few sources are citing each other [8]. A steep increase of mining started after 1965 and the production surpassed 50,000 t in the late 1980s. In 2015 the total RE oxide production reached about 175,000 t including illegal mining [9].

The share of REO, which is converted to metal by electrolysis, can be approximated from two sides. First by taking the mining of oxides as a basis and second by taking the NdFeB-magnet production as a basis. Both approaches are compared for the years 2010 until 2015 (Fig. 2).

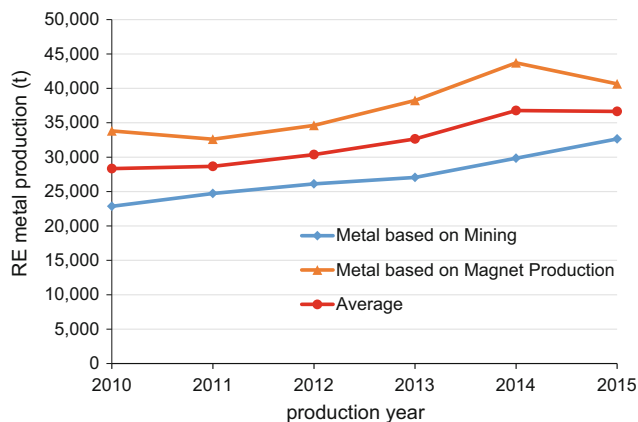

Fig. 2 Comparison of the RE metal production estimates based on mining of rare earth oxides [9] versus magnet production [10]

Table 1 Rare earth oxide (REO) production [9] and assumption of metal production by electrolysis

Year	China quota REO (t)	Illegal mining REO (t)	ROW REO (t)	Global REO (t)	Nd/Pr metal by electrolysis (t)	Other metal by electrolysis (t)	Sum of metal by electrolysis (t)
2010	89,200	28,300	5000	122,500	19,870	2980	22,850
2011	93,800	32,700	6000	132,500	21,492	3224	24,716
2012	93,800	38,200	8000	140,000	22,708	3406	26,115
2013	93,800	39,200	12,000	145,000	23,519	3528	27,047
2014	105,000	39,250	15,750	160,000	25,952	3893	29,845
2015	105,000	47,000	23,000	175,000	28,386	4258	32,643

1. The global annual RE oxide production is based on the official mining quota from China [10] plus an individual estimate of illegal mining by Kingsnorth [9] plus the rest-of-world (ROW) production. In average about 20% of the total REO is Nd/Pr oxide. It is assumed that a share of 95% of Nd/Pr oxides are converted to metal by electrolysis. The weight of oxide is converted to metal with an average of 85%. For other RE metals produced by electrolysis like mischmetal and dysprosium an additional 15% of the Nd–Pr content is assumed. Combined a ratio of about 18.7% metal production by electrolysis to the total RE oxide mining is attained (Table 1).
2. The annual production of NdFeB-magnets in China [10] can be extrapolated to the world production, by assuming that 10% of the magnet production is located outside China [9]. The metal smelting of RE metal exports is conducted in China. The Nd–Pr metal share by weight of the magnet is about 30% [2]. It is assumed that 5% Nd/Pr is lost while manufacturing magnets. Presuming an amount of other RE metal production of 15% of the Nd–Pr amount, the total amount of RE metals produced by electrolysis can be calculated with a total ratio of about 40% to the Chinese magnet production.

Figure 2 compares the amounts of RE metal production based on both approaches. The production amount of the mining approach is on average 10,000 t/a lower than the approach based on magnet production. The deviation is quite high due to the uncertainty of the estimates of both approaches. For magnet production, a small amount of recycled Nd–Pr is used, but it should not lower the primary production significantly. In the mining approach, the uncertainty seems to be bigger, because it is difficult to get precise and reliable data of the worldwide REO production.

The metal production by electrolysis for the PFC estimate will be based on the magnet data subtracting the average deviation. The amount of RE metal produced by electrolysis between 2000 and 2015 is calculated accordingly and depicted in the Fig. 3. In 2015 the Chinese NdFeB-magnet production reached about 100,000 t leading to a RE metal

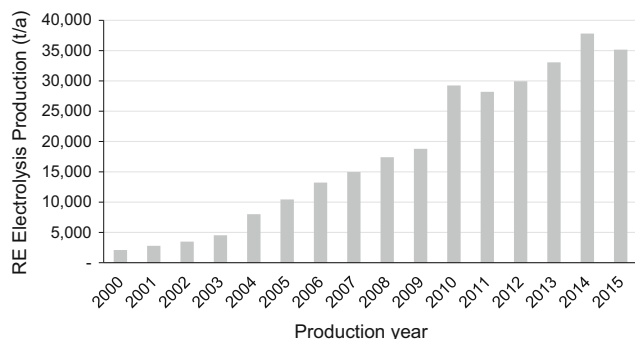

Fig. 3 Estimate of the annual RE electrolysis production

production of about 35,000 t. The dataset could be improved by taking the Chinese and ROW development of the magnet industry into account and including dynamic industry data for other metallurgical RE metal consumption.

Estimate of PFC Emission by Rare Earth Electrolysis

The estimate of PFC emission is based on three approaches. First, the anodic off-gases are analyzed while conducting a laboratory neodymium electrolysis. Second, the emission is based on fluoride raw material usage. Third, the emission is derived by comparing the rare earth system to the aluminum electrolysis. To calculate the total PFC emission per year, the approximation of metal production (Fig. 3) is taken into account.

Theory of PFC Emission of the Neodymium Electrolysis

The free Gibbs energy and enthalpy of reaction of the electrolytic system of Nd_2O_3 dissolved in $\text{NdF}_3\text{-LiF}$ electrolyte reacting with a carbon anode can be calculated for the temperature of 1050 °C. The predominant reaction is:

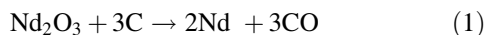

Figure 4 shows the theoretical voltage of the relevant anodic products of Nd_2O_3 and NdF_3 reacting with carbon and also with H_2O . The theoretical decomposition voltage (based on ΔG), at which the reaction is enabled, is shown in red, while the green boxes show the thermoneutral voltage (based on ΔH), where the thermochemical equilibrium is reached. The energies are calculated by FactSageTM 6.4 (Data: Fact PS, FT Salt). Because of the chemical similarity of the RE elements, the forming potentials do not vary significantly for other RE elements.

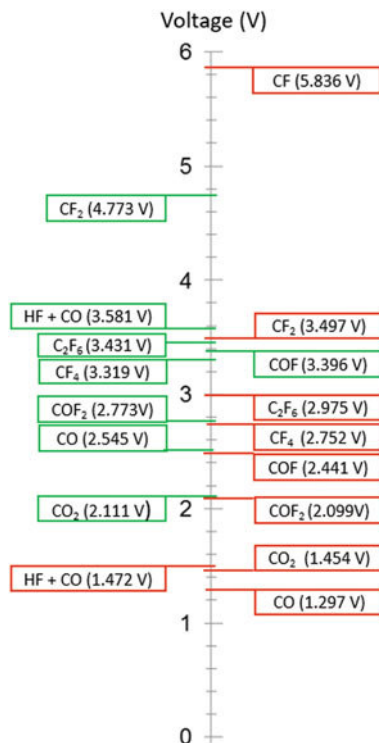

Fig. 4 Theoretical decomposition voltage (red) of Nd_2O_3 with carbon anode marked with the anodic products, green the thermo-neutral voltage of the same reaction, both at 1050 °C, FactSageTM 6.4 (Data Fact PS, FT Salt)

The first and most likely reaction by thermochemical means forms the anodic product CO. It is followed by CO_2 . A potential increase of 802 mV enables the first fluoride containing anode gas. COF_2 is an unstable molecule and reacts with partners to CF_4 . The direct formation of CF_4 is enabled 1455 mV higher than CO and C_2F_6 is enabled 1678 mV higher than CO. The exact anode potential of the industrial process determining the anode product formation is not known but can be close or higher than the direct CF_4 enabling potential. The very high voltage of 11 V in the industrial cell is mainly caused by the big anode cathode distance. The ohmic resistance of the electrolyte leads to a high voltage drop necessary for the heating of the cell.

The reaction kinetics have to be considered as well. If the concentration of oxide at the anode becomes low, the formation potential of oxygen containing anode products increases, making the fluoride product more likely to form. The oxide solubility of the $\text{NdF}_3\text{-LiF}$ electrolyte is quite low with just about 4% probably leading to a fast starving electrolyte.

In addition, the temperature variation and especially the anodic current density determine the anode reaction. A more detailed analysis of the anodic gas formation is published in [7].

Experimental Study of PFC Emission by the Rare Earth Electrolysis

To determine the anodic emission, which is dependent on the voltage, the current density and the oxide concentration, a laboratory electrolysis was built, similar to the industrial setup with a center cathode and surrounding anode. The electrolyte raw material are 99.9% pure NdF_3 (Treibacher AG), 99.85% pure LiF and 99.9% pure Nd_2O_3 (Alfa Aesar GmbH & Co KG). The fine powder is dried over night at 300 °C. The fluorides are mixed with a composition of 87.5% NdF_3 and 12.5% LiF . This mixture is pre-melted in a high purity graphite crucible in a sealed induction furnace at 1.4 bar argon 5.0 atmosphere. The liquid is homogenized by shortly superheating the melt and casting it in a narrow graphite mold resulting in rapid solidification. About 2 kg of this solid basic electrolyte is put in a graphite crucible (SIGRAFINE® R8510; SGL Carbon) with an inner diameter of 10 cm. Similar to the industrial cell set-up a tungsten rod of 8 mm diameter is used in the center as the cathode (99.95%; PLM GmbH). Around the cathode is a hollow graphite cylinder anode (SIGRAFINE® R8510; SGL Carbon) with an inner diameter of 7.5 cm. A molybdenum crucible is put underneath the cathode to collect the liquid neodymium. The high temperature steel cell is heated by a SiC heated furnace to control the temperature at 1050 °C. Through the water cooled lid of the steel cell a Pt-PtRh thermocouple with a molybdenum sheath (Omega Engineering GmbH) is fitted into the electrolyte. The cell is flushed with pure argon 5.0 at 3.0 l/min. The voltammetry measurements are conducted by a potentiostat with a 40 A booster (Ivium Technologies). To determine the oxygen concentration of the electrolyte, samples are taken from the liquid with a pure glass pipettes (HSQ300; Quarzglas Heinrich). The solidified samples are analyzed 3–5 times by the carrier gas method (Leco). The anodic gas measurement is achieved by pumping 1 l/min off-gas at 180 °C in the

FT-IR-spectrometer (Gasetm, Ansyco), which is calibrated for CO , CO_2 , CF_4 and C_2F_6 . The measuring interval is set to 7 s.

Linear voltammograms with simultaneous gas measurement are published in more detail [7]. The general observation of the compound occurrence in dependence on the potential is in good accordance with the theoretical calculations. A typical linear voltammogram is shown in Fig. 5. The current can flow when the decomposition voltage for the first reaction is enabled. This is CO , followed by a small ration of CO_2 at higher voltage. The current rises linear, with small noise, due to bubble formation and fast removal until it drops sharply where most probably the first fluoride compound is formed, briefly passivating parts of the anode surface. This effect can be termed as the partial anode effect. With the enabling reaction of CF_4 the current rises again, with a lower degree, because of the increasing anode coverage by CF_4 gas bubble layers. At a distinct voltage, the current drops back to almost zero, caused by a complete passivation of the anodic surface, which probably is itself caused by the formation of a solid CF layer. This effect is termed the full anode effect [7].

To quantify the anodic product of the electrolytic process, the cell voltage for each step of a stair case voltammetry between 2.0 and 5.0 V is maintained for 5 min to reach a steady current and gas concentration. The temperature is set to 1050 °C and the electrolyte mass is 1970 g. The hollow cylinder anode immerses 2.7 cm into the electrolyte leading to an anode current density below 0.3 A/cm².

Figure 6 shows the concentration of CO , CO_2 , CF_4 and C_2F_6 . The value of CO is divided by 10 to fit in the scale, while the concentrations for CF_4 and C_2F_6 are multiplied by 10 to show them in same scale. At 2.5 V cell voltage, the first anode product is measured. It is CO showing the presence of oxygen in the electrolyte. Even though the powder was dried before, there has to be an oxygen impurity in the system, probably water. The detection of CF_4 starts at

Fig. 5 Typical linear sweep of the system Nd_2O_3 – NdF_3 – LiF with the start of anodic product formation in dependence on the cell voltage

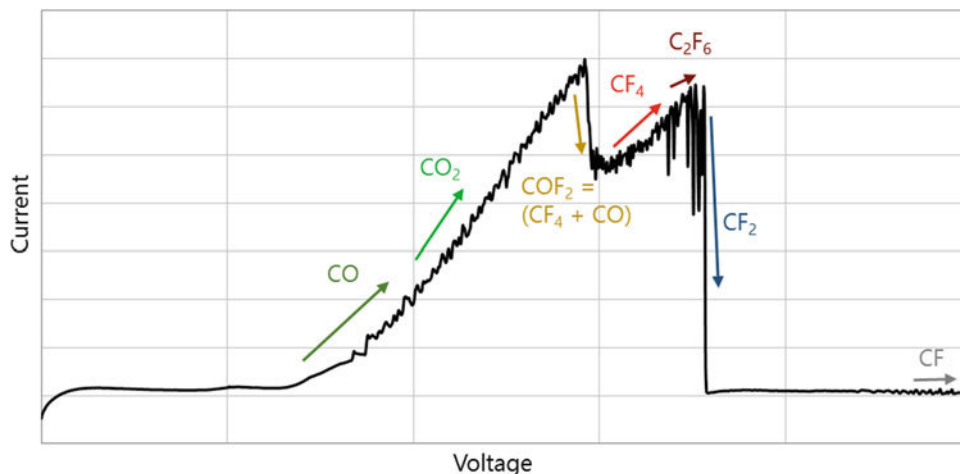

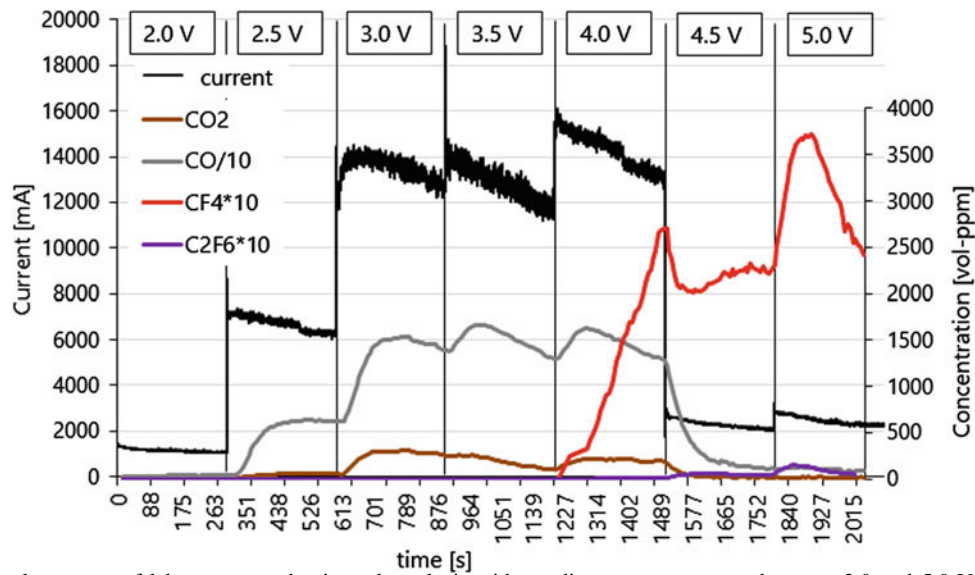

Fig. 6 Staircase voltammetry of laboratory neodymium electrolysis with anodic gas measurement between 2.0 and 5.0 V without feeding of Nd_2O_3

the 4.0 V step and increases continuously for five minutes until it drops to a lower level at 4.5 V where the current also drops dramatically from about 14 A to only 2 A. At 5 V the current stays at low level, but the CF_4 concentration increases again and also C_2F_6 is detected in good accordance with the theoretical calculation.

The concentration values are quite different after feeding the electrolyte with 2% Nd_2O_3 as seen in Fig. 7.

CO_2 reaches concentrations ten times higher after feeding than before. The CF_4 concentration is first detected at 4.5 V and reaches lower values than before. A comparison by

percentage of the off-gas before and after feeding is shown in Fig. 8.

The CF_4 concentration reaches more than 20% of the anodic gases without feeding but only about 7% after feeding. C_2F_6 is detected at a very low oxide concentration with almost 1% of the off-gas but only in negligible traces after feeding the electrolyte with 2% oxide.

Galvanostatic electrolysis experiments with a duration of an hour show that the process starts without PFC emission. Without feeding the electrolyte depletes of oxygen over time and the CF_4 formation starts slowly and grows to a stable

Fig. 7 Staircase voltammetry of laboratory neodymium electrolysis with anodic gas measurement between 2.0 and 5.0 V after feeding 2% Nd_2O_3

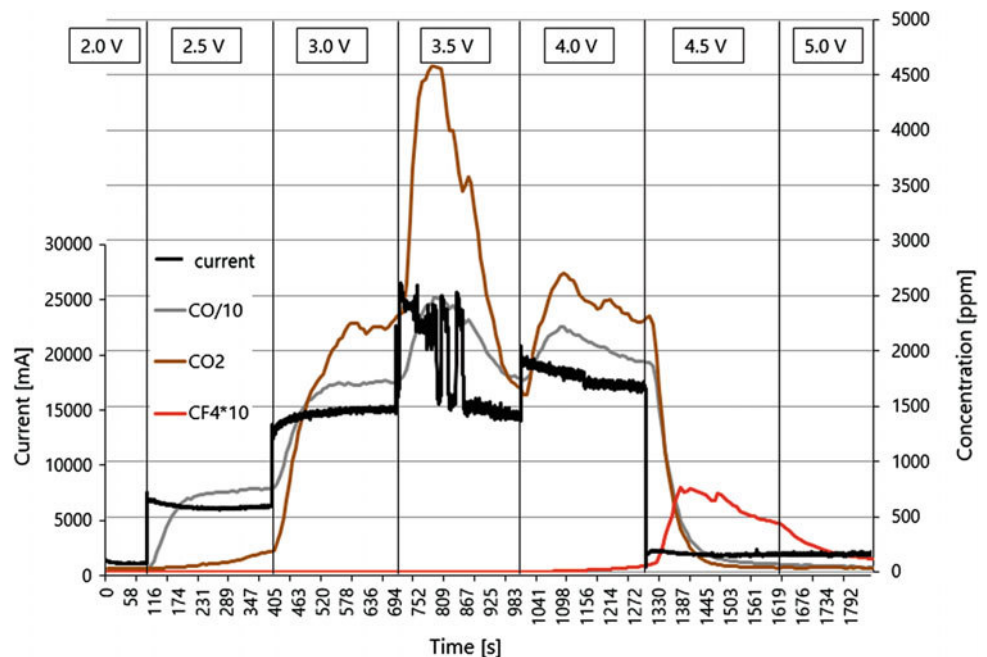
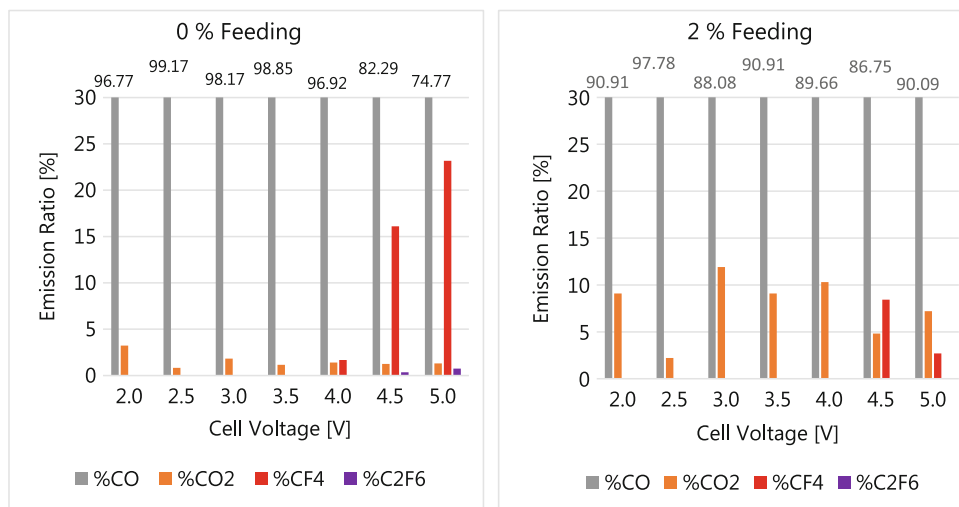

Fig. 8 Comparison of the gas emission from laboratory neodymium electrolysis without and after feeding 2% Nd_2O_3 (values for CO are above the bars)



emission of up to 36% of the total emission. C_2F_6 is measured with a percentage of 4% and the balance of 60% is CO, while almost no CO_2 is detected. In addition, no other compounds as C_3F_8 , COF_2 or OF_2 are found in the off-gas. The voltage remains stable and the anode is not passivated as expected from the anode effects happening in the aluminium electrolysis. No anode effect would be detected and the process runs with high PFC emission [15].

The same sudden increases in cell voltage as known from the anode effects of the aluminum electrolysis were also found. This anode effect reaches 10 V, the set limit of the rectifier. The voltage above 5 V here for more than one minute is detected as an anode effect by the programmable process controller of the laboratory electrolysis, which initiates the feeding of 1% Nd_2O_3 automatically. Before terminating the anode effect by feeding the cell, the CF_4 concentration reaches about 1% of the former CO concentration. With the addition of Nd_2O_3 , the voltage drops immediately and the unwanted emission of CF_4 and also water and HF, which originates from the humid oxide feed returns to almost zero [15].

This experimental findings lead to the conclusion that the RE electrolysis can easily run on frequent to continuous PFC emission with a ratio of about 7% CF_4 and 0.7% C_2F_6 of the total emission, where CO is basically the balance in laboratory system. CO in the industrial process would burn to CO_2 in the oxygen-containing atmosphere.

The extensive analysis of the RE electrolysis by Keller et al. [11, 12] suggests a frequent and massive PFC emission, because operational problems are alleviated by electrolyzing neodymium fluoride. This is confirmed by industry data showing the consumption of about 0.11 kg NdF_3 per kilogram neodymium produced [13].

By maintaining a high oxide concentration in the electrolyte and an adequate cell voltage, the RE electrolysis can be conducted with low PFC emission. However, more likely

will be the occurrence of many anode effects if not for long time continually emitting PFCs due to the lack of an automated process control being able to feed if necessary and reduce the distance between the electrodes. The dynamic behavior of cell voltage of the neodymium electrolysis in dependence of the oxide concentration is analyzed [15]. It shows the low increase in cell voltage at very low oxide concentration, making a process control in example of the aluminum electrolysis difficult but possible.

Industrial experiments of various technologies have to show the real emission by RE smelting.

Scenarios of the Annual PFC Emission by Rare Earth Industry

The estimate of the amount of annual PFC emission should show the potential contribution of the RE industry to global warming. Due to the lack of industry data, three scenarios are proposed. First, a worst-case scenario with a continuous PFC emission based on laboratory measurement is described. Second, a medium-emission scenario based on industry data of the specific fluoride consumption is made. Third, a best-case scenario is proposed with PFC emission just in case of the rare events of anode effects of a well maintained process.

The worst-case emission scenario assumes a continuous PFC emission by RE electrolysis. The continuous emission can be higher than 50% as shown [15], but with regular feeding it should remain much lower. The measurements as shown in Figs. 7 and 8 suggest a CF_4 concentration of about 7% in case of strong CF_4 formation. Usually C_2F_6 is measured with about one tenth of the CF_4 amount. Hence, C_2F_6 is assumed to be emitted continuously with 0.7% at a current efficiency of 80%. PFCs will not reoxidize, which increases the total emission. The balance is regarded as CO, which

converts in the atmosphere to CO_2 . If CO_2 would be the only emission in the off-gas, a mass of only about 0.5 kg CO_2 are formed by the anodic reaction. In 2015, the total amount of CO_2 -eq would be about 17,600 t. Hence, only the PFC emission is a relevant greenhouse gas contributor. On this basis the mass of 739 g CF_4 per kilogram RE are emitted, which equals 548 kg CO_2 -eq. The mass of C_2F_6 formed per kilogram is 116 g, which equals 142 kg CO_2 -eq, if the value of CO_2 -eq of CF_4 with 7 390 and of C_2F_6 with 12,200 are used [17]. The CO_2 -equivalents per kilogram neodymium metal of CF_4 , C_2F_6 and CO_2 sum up to about 690 kg. The other RE metals have by ratio a similar mass like neodymium. This is why this calculation is extrapolated to the overall RE electrolysis emission survey.

The medium-emission scenario takes published raw material data as its basis. Neodymium fluoride is added to the electrolyte to maintain the ratio of about 87%. Industry data show the consumption of 0.11 kg NdF_3 per kilogram neodymium produced [13]. Another recent publication mentions the ratio of 10% NdF_3 taking part in the electrode reactions [18]. In this scenario, the consumed amount of NdF_3 is regarded to convert into CF_4 and C_2F_6 with the ratio of 10 to 1. It is further assumed, that 10% of the NdF_3 mass leaves the process by particulate emission or with metal tapping. This results in a CF_4 mass of 30 g/kg RE metal and a C_2F_6 mass of 3 g/kg RE metal produced. The total CO_2 -eq sums up to 256 kg/kg_{RE}. In 2015 this gives a total CO_2 -eq emission of about 9,000,000 t.

The best-case scenario considers the RE electrolysis to be on the technological level of the aluminum electrolysis in the 1990. The anode effect frequency and duration led to a specific PFC emission at about 5 kg CO_2 -eq per kilogram aluminum. Taking this specific PFC emission as a basis and fitting it to the RE system, a CO_2 -eq of about 1 kg per kilogram RE metal is calculated. The high molar mass of RE metals is the reason why the neodymium electrolysis emission is smaller. With the normal CO emission converted to CO_2 , a sum of 1.5 kg CO_2 -eq/kg_{Nd} is calculated. This sums up to about 53,000 t CO_2 -eq in 2015.

Figure 9 shows the comparison of the annual emission of the three scenarios. The amount of RE metal produced by electrolysis, as calculated in Chapter 2, is multiplied with the CO_2 -equivalent of CF_4 and C_2F_6 emitted per ton of RE metal.

Based on the first Chinese industrial measurements, a total value of only 17,000 t CO_2 -eq by PFC emission is calculated [19], because a very low amount of CF_4 and C_2F_6 was detected in the off-gas while anode effects occurred. This number does not match with the high fluoride consumption of the process and the anodic reaction with fluoride. Possibly the process is controlled at a high level. The question remains how representative this published data are.

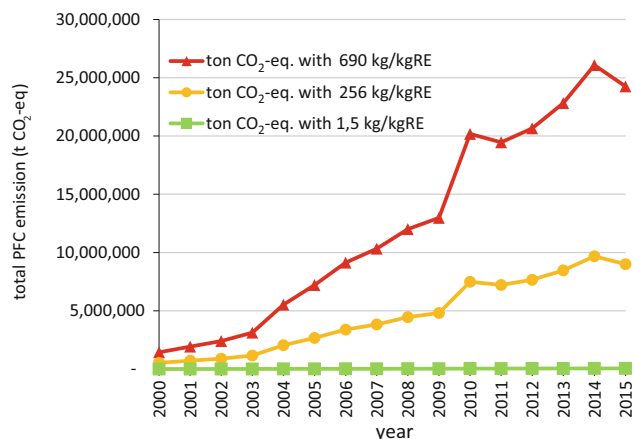

Fig. 9 Scenarios of the annual greenhouse gas emission from rare earth electrolysis

Probably, the average reality is closer to the medium-emission scenario. By this scenario an amount of up to 10 million t CO_2 -eq is emitted per year. This sums up from 29.5 g CF_4 per kg_{RE} and 3.1 g C_2F_6 per kg_{RE}. For 2015 the amount of 1.038 kt CF_4 and 0.109 kt C_2F_6 would be emitted. The open gap of PFC emission between atmospheric measurement data and industrial reports of about 3 kt could be closed by one third [16].

Regional Distribution of PFC Emission

The RE smelting industry is located in China and some small capacities exist in Vietnam and Laos close to the border of China. Nowadays the smelting capacity in Japan is negligible and western companies are not running the process in significant scale. With Chinese joint ventures, Japanese companies like Shin-Etsu, Showa Denko and Sumitomo smelt primarily neodymium in the border region of Vietnam and Laos for the Japanese magnet industry. They use Chinese REO, most probably from the Sichuan and southern China region and smelt the metal with Chinese electrolysis cell technology.

Otherwise, it is assumed that the smelters are in the same region as the mines. The biggest production site is in Baotou, Inner Mongolia, followed by the Sichuan region and many places in southern China. The regional distribution can be estimated by the amount of light RE metal produced in different companies. The southern Chinese companies are focused on heavy RE metals, which are converted to metal by electrolysis in a negligible quantity. By extracting heavy RE oxides there are also light RE oxides separated and smelted to metal. The exact location of smelters are not always known, not to forget about the possibility of up to 40% not documented or illegal mining and production of RE

Table 2 RE companies with their region of mining in 2015 [10]

Region	Group	Company	Mining quota (t)	REO
Baotou—Inner Mongolia	North RE Group	Inner Mongolia Baotou Steel Union Co., Ltd	59.500	Light RE
Sichuan	South RE Group	Jiangxi Copper Rare Earth Co., Ltd	14.400	Light RE
Sichuan/Guangxi	Central Government Owned Enterprises	Aluminum Corporation of China	3.600	Light/Heavy
Sichuan/Guangxi	Rest	Others	10.600	Light RE
Fujian (Southern China)	Others Groups	Xiamen Tungsten Co., Ltd	2.000	Heavy RE
Hunan (Southern China)	Central Government Owned Enterprises	China Minmetals Corporation	2.000	Light/Heavy
Jiangxi (Southern China)	South RE Group	Ganzhou Rare Earth Industry Co., Ltd	9.000	Heavy RE
Guangdong (Southern China)	Others Groups	Rising Nonferrous Metals Share Ltd	2.200	Heavy RE

metals. The Chinese government plans to consolidate the industry and gives permission only to six big groups for smelting RE [14].

Table 2 shows the light, light/heavy and heavy RE quota of the major group companies and their mining area 2015. The share of light rare earth mining is directly correlated to the production of RE metal by electrolysis.

Baotou produces mainly light RE metals and the quota is known. A share of 64% of the total metal production by electrolysis is assigned to Baotou. Some companies mine RE in the Sichuan region and southern China. They have a mixed light-heavy RE quota, so their share of light RE metals converted to metal by electrolysis is assumed as 60% and assigned to the Sichuan region with a share in sum of 24%. The southern China companies mainly produces heavy RE elements. Their share of light RE metals compared to their heavy RE quota is assumed as 20%. A share of 7% results for the region in southern China. 5% are assumed to be smelted in the border region of Laos and Vietnam. With high uncertainty of the data, the estimate shows the distribution of electrolysis and by this the distribution of PFC emission as shown in Fig. 10. Technological aspects of PFC emission are not included. The share of emission in southern China can be higher due traditionally smaller companies with a lower technological standard.

Conclusion

This work gives an assumption of the RE metal production by oxide electrolysis in a fluoride electrolyte. In 2015 about 35,000 t RE metal are smelted with an uncertainty of about $\pm 15,000$ t. The experimental research on quantitative

PFC emission in the off-gas of a neodymium electrolysis suggests the possibility of a continuous PFC generation with 739 g CF_4 and 116 g C_2F_6 per kilogram RE metal produced. Based on this, the worst-case scenario would lead to a PFC emission of about 24,000,000 t CO_2 -eq in 2015. Because of the technical difficulty in comparing the laboratory system to the real process, the uncertainty of the measurement can be as high as 100%. The medium-emission scenario calculates by raw material consumption a mass of 30 g of CF_4 and 3 g of C_2F_6 , which equals a CO_2 emission of about 9,000,000 t in 2015. This total amount is calculated with an uncertainty of about $\pm 50\%$ due to the uncertainty of metal production and loss of fluorides. The best-case scenario compares the PFC emission of RE smelting to the aluminum smelting of the 1990s. Based on the analogy, the amount of annual PFC emission would be about 53,000 t CO_2 -eq in 2015, which is—compared to the other scenarios—an uncritical quantity.

The distribution and quantity of mining activities in China lead to an estimate of the regional emission distribution. Accordingly, the highest amount of PFC is emitted in Baotou followed by the Sichuan region. The minority is emitted in southern China and in the border area of Vietnam and Laos. The not documented mining and smelting of up to 40% [9] leads to an uncertainty in the same order of magnitude for the distribution of PFC emission. To determine the real range and location of PFC emission, industrial off-gas measurements have to be undertaken. Even if the reality is lower than the medium-emission scenario, the improvement of the electrolysis process should be a primary goal of the RE industry to lower PFC emission.

This research was partially funded by Siemens AG with the project “Rare Earth—Green Mining and Separation” at the RWTH Aachen University, Germany.

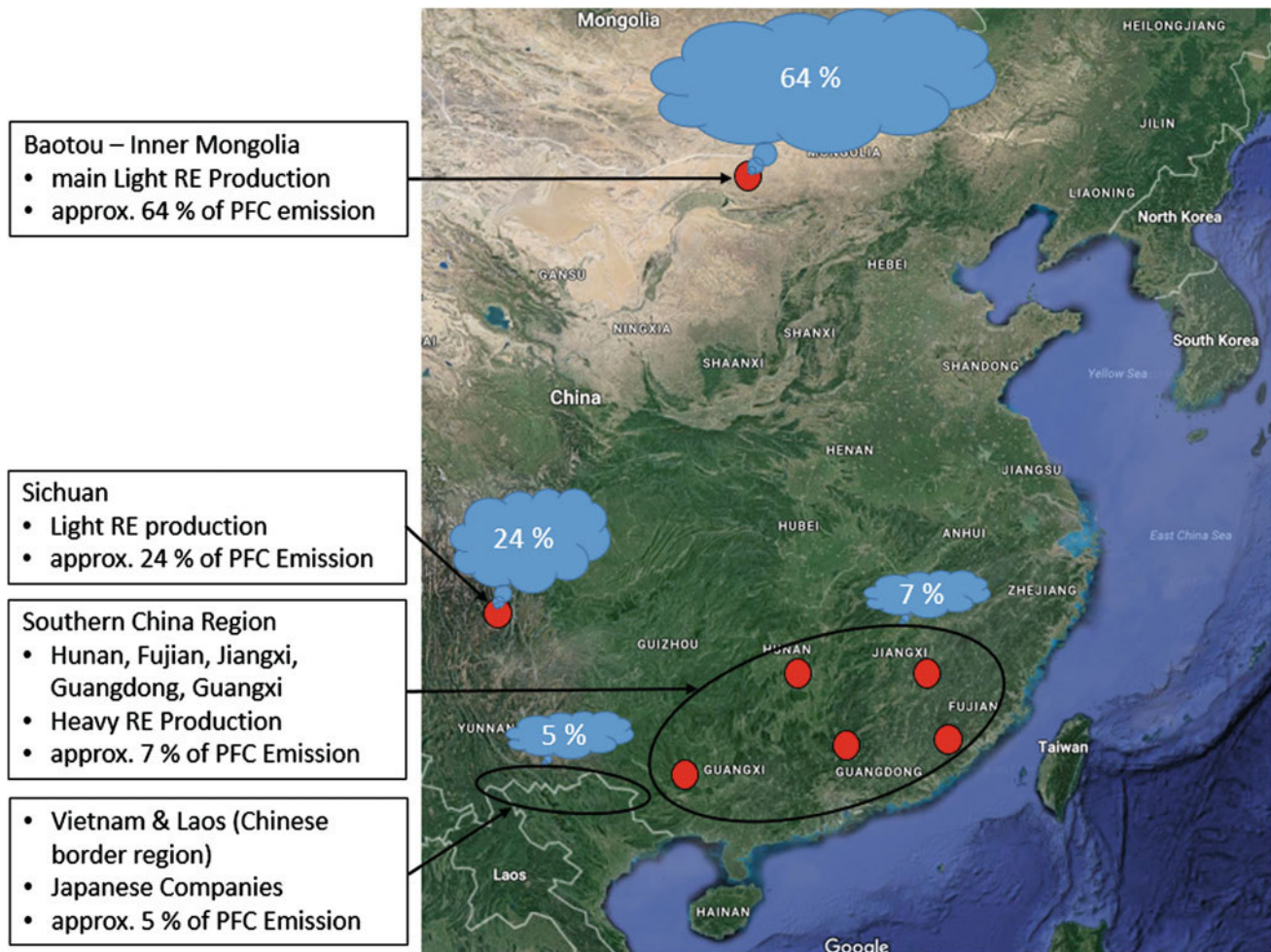

Fig. 10 Regional distribution of PFC emission assumed for rare earth smelting

References

1. Keller, R.: Cell design for the electrolysis of neodymium oxide. In: Bautista, R., Mishra, B. (Hrsg.): Rare Earths and Actinides: Science, Technology and Applications IV 2000.
2. Gupta, C. K.; Krishnamurthy, N.: Extractive metallurgy of rare earths. Boca Raton, Fla 2005.
3. Vogel H.; Friedrich B.: Development and Research Trends of the Neodymium Electrolysis—A Literature Review. In: GDMB (Hrsg.): Proceedings of the 8th European Metallurgical Conference (EMC) 2015.
4. Xie-Liying: The industry current situation and development prediction of neodymium metal. In: Rare Earth Information Market Review 254 (2005).
5. Fu Shi (2007) Present Condition of Research and Developing Trend in the Rare Earth Electrolysis Cell. Journal of the Chinese Rare Earth Society 25: 71–76.
6. Chen D. et al.: Key Technologies of 3000A Submerged-Liquid Cathodic Rare Earth Electrolysis Process. In: Journal of the Chinese Rare Earth Society 29 (2011) 6, 769–72.
7. Vogel, H., Flerus, B., Stoffner, F. and Friedrich, B. (2017) Reducing Greenhouse Gas Emission from the Neodymium Oxide Electrolysis: Part I: Analysis of Anodic Gas Formation. Journal of Sustainable Metallurgy, 3, 99–107. <http://doi.org/10.1007/s40831-016-0086-0>.
8. Zepf, V.: Rare earth elements. A new approach to the nexus of supply, demand and use—as exemplified by the use of neodymium in permanent magnets. Berlin 2013.
9. Kingsnorth D.: The Global Rare Earth Industry Today - Plagued by Illegal Production in China. 11th Rare Earth Conference, Metal Events Ltd., Singapore, 2015.
10. JL MAG Rare-Earth Co., Ltd. (Hrsg.): Rare Earth Magnet Supply and Demand. 11th Rare Earth Conference, Metal Events Ltd., Singapore, 2015.
11. Keller, R.; Larimer, K. T.: Anode effect in neodymium oxide electrolysis. In: Rare earths science, technology & applications III/IX (1997) IX, S. 175–80.
12. Keller, R.; Larimer, K. T.: Electrolysis of Neodymium Oxide. Final Report 1991 through 1997 for U.S. Department of Energy 1997.
13. Bao J.: Research on Raising the Utilization Ratio of Nd_2O_3 in Electrolysis Process. In: Rare Metals Letters 23 (2004) 7, S. 35–36.
14. Yang M.: Securities Daily. China Minmetals Corporation obtained further admission by “1 + 5” policy, 2014.
15. Vogel, H. and Friedrich, B. (2017) Reducing Greenhouse Gas Emission from the Neodymium Oxide Electrolysis. Part II: Basics of a Process Control Avoiding PFC Emission. International

- Journal of Nonferrous Metallurgy, 6, 27–46. <http://doi.org/10.4236/ijnm.2017.63003>.
16. Wong, D.S., Fraser, P., Lavoie, P. et al. PFC Emissions from Detected Versus Nondetected Anode Effects in the Aluminum Industry. JOM (2015) 67: 342. <http://doi.org/10.1007/s11837-014-1265-8>.
 17. Hall C. (2009) Key Greenhouse Gases and Global Warming Potentials. http://www.ipcc.ch/publications_and_data/publications_and_data/ipcc_fourth_assessment_report_wg1_report_the_physical_science_basis.htm.
 18. Li B., Liu S., Wang H. et al. (2014) Electrochemistry for Nd Electrowinning from Fluoride-Oxide Molten Salts. In: Rare Metal Technology 2014 TMS. Wiley, Inc, pp 95–98.
 19. Zhang L., Wang X., Gong B.: Perfluorocarbon emissions from electrolytic reduction of rare earth metals in fluoride/oxide systems. Atmospheric Pollution Research (2017) 1–5.