

Examination of an alternative method for the pyrometallurgical production of copper-chromium alloys

J. Brenk, S. Hassan-Pour, P. Spiess, B. Friedrich

IME – Metallurgische Prozesstechnik und Metallrecycling, RWTH Aachen, Germany

jbrenk@ime-aachen.de

Abstract. In this paper an alternative to the usual route for the production of copper-chromium alloys by Hot Isostatic Pressing (HIP) followed by Vacuum Arc Remelting (VAR) is investigated. Therefore the HIP is replaced by an aluminothermic reduction. As oxidizing agents for this aluminothermic reduction (ATR) chromium oxide (Cr_2O_3) and copper oxide (CuO) are used. These oxidants are mixed in a stoichiometric relation with aluminium (Al) to get the following aluminothermic reactions going:



As ATRs always are exothermic reductions, it is important to control the heat output of the reaction. A common simplification for the heat calculation in the field of ATR is the “Shemshushny Factor” (Sh-Factor). This factor determines the rate of energy input per reactant mass:

$$Sh = \frac{\sum H_r}{\sum m}$$

To avoid a secondary melt phase after ATR, inline casting is used to directly obtain vacuum arc remeltable electrodes out of the liquid melt of the ATR.

The second part of this work deals with the remelting of these electrodes via VAR. The first VAR trials aim at finding process parameters for remelting a copper-chromium ingot. As demixing is to avoid, it is necessary to control process parameters within a small range to obtain a shallow melt pool.

1. Introduction

Copper-chromium (CuCr) alloys play a very important role in the field of medium voltage switch contacts. The combination of high thermal and electrical conductivity with high strength and a high arc resistance make it the adequate material for these switches. Compared to pure copper the chromium added to the copper matrix increases the resistance against contact breaking sparks. As these sparks are unavoidable and carry an enormous amount of energy at voltages of 1 kV to 145 kV, pure copper would melt which could result in welding the switch contacts together in the worst case. [1]

The challenge coming with CuCr alloys is that there is a miscibility gap in the system of CuCr. [2][3][4] Therefore the process of producing CuCr alloys consists of two complex process steps: consolidation of an electrode and refining of that electrode. The main target of the consolidation step is to achieve a uniform distribution of Cr in the Cu-matrix. This is mostly achieved by hot isostatic pressing. The following remelting step is necessary to receive a homogenous microstructure and to control material-

and solidification defects. In this work the consolidation step of hot isostatic pressing is replaced by an aluminothermic reduction followed by vacuum arc remelting (VAR). The objective is to find a technical usable alloying composition that is feasible regarding its final aluminium content.

2. Fundamentals

As mentioned above the production of CuCr alloys will be carried out via an aluminothermic reduction followed by a refining step in the VAR.

2.1. Aluminothermic reduction

The aluminothermic reduction is defined as a reaction between a metal oxide of the target metal(s) and metallic aluminium as reducing agent. During this reaction a metal phase consisting of the target metal(s) and a slag are formed. This slag mainly consists of Al_2O_3 but also other slag forming components such as CaO can be added to the system. The principle behind the aluminothermic reduction is the different affinity for oxygen of the target metal(s) compared to aluminium. If this difference is big enough the aluminothermic reduction is distinguished by a strong exothermic behaviour and very high reaction rates. [5]

For the present investigation the two target metals are added as oxides and react as following:

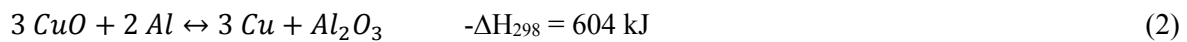
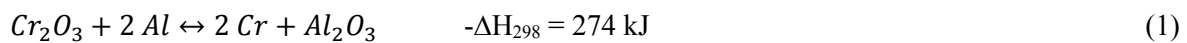

For all aluminothermic reductions the energy density of the system has to be adjusted properly in order to get a self-propagating reaction front going on the one hand and to not have a dangerously high energy in the system on the other hand. An estimation for the energy density of the system is the so called "Shemshushny Factor" (Sh-Factor). This factor is defined as the amount of energy brought into the system as reaction enthalpy divided by the total mass of the system: [6]

$$Sh = \frac{\sum H_r}{\sum m}$$

Usually to keep an aluminothermic reduction going so called boosters need to be added to the system to raise the energy level of the whole system. Boosters are substances that react with the reducing agent, aluminium, very exothermically and by that add a lot of energy to the system. The products of the reaction between booster and aluminium have to go into the slag or even evaporate to not contaminate the target metal/alloy. But as seen in equation (2) the reaction between CuO and Al is very exothermic. This means that for the system CuCr no boosters are needed. The energy level is even so high that some kind of cooling agent needs to be used to lower the Sh-Factor of the system. In the trials described in this paper lime (CaO) was used to lower the Sh-Factor. Lime on the one hand consumes energy as it is heated up and molten throughout the process and on the other hand helps forming the slag.

2.1.1. Inline casting.

As the material produced via ATR has to be remelted in the VAR, it needs to have the typical cylindrical shape of VAR electrodes. Usually the metal produced via ATR solidifies in the ATR reactor and therefore has a round, disk like shape. To obtain the cylindrical electrode shape the material would have to be remelted, for example in a vacuum induction furnace (VIM), and cast into a cylindrical mould.

The approach of this work is the so called inline casting. This means that the electrodes are cast directly out of the ATR process. A cylindrical mould is attached to the bottom of the ATR reactor to obtain the desired shape of the electrode. The connection between reactor and mould is closed with a small metal plate which melts as soon as the reaction reaches the bottom of the reactor. In this way the molten metal can flow into the mould but not slag or unreacted material.

2.2 Vacuum arc remelting

The vacuum arc remelting is a process where a consumable electrode is being remelted into a water cooled copper mould under a vacuum ($\sim 10^{-3}$ mbar). In general at VAR the energy input is inserted into the metal by an electric arc induced by a direct current between the electrode and the mould or later the ingot. As seen on figure 1 this leads to a dripping of the metal from the electrode to a melt pool inside of the mould.

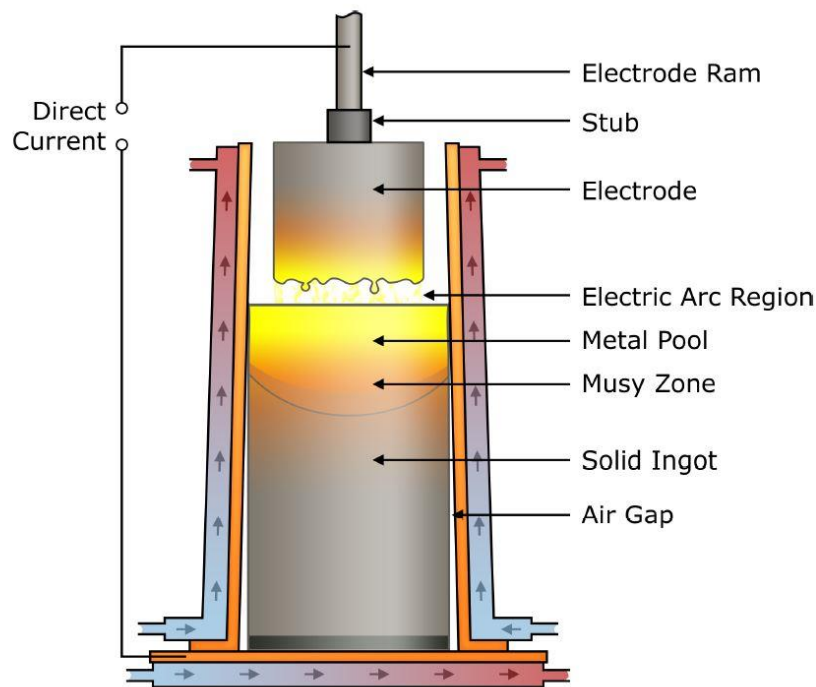

Figure 1: Schematic procedure of vacuum arc remelting

By that it is possible to refine the metal in several ways. First it is possible to remove dissolved gases and volatile elements very easily. This is possible because of the low furnace pressure combined with a very large phase boundary between metal and vacuum. The size of the phase boundary is that big because all the metal from the consumable electrode is dripping to the mould as very small droplets. For this work it means that it is possible to get rid of the unwanted aluminium content up to a certain limit. Second it is possible to get rid of non-metallic inclusions (NMIs) as they will be transferred to the mould walls by a combination of convection and electromagnetic forces caused by the electric arc. So if there are remaining slag particles from the ATR-process they will not survive VAR and therefore not be in the final metal block.

Third there will be a certain solidification structure of the ingot that can be controlled by melt power and cooling rate. [7][8]

3. Experimental Procedure

The experimental procedure of this work basically consists of three parts:

1. The ATR with the focus on finding a mixture that is of technical relevance and which has a low aluminium content.
2. The inline casting to obtain an electrode usable in the VAR.
3. The VAR to remove NMIs and to homogenize the ingot.

3.1. Aluminothermic reduction

The aim of the investigations regarding ATR is to find a mixture of copper and chromium that is of technical relevance and that is producible via ATR with reasonable losses and with an aluminium content as low as possible. So firstly there are calculations with a thermodynamic database necessary to select promising mixtures of Cu and Cr. The most promising mixtures then are tried out in first small trials in a 16 kg scale. This size, although seeming quite big, has been chosen because slag separation for smaller ATRs is not satisfactory.

As input mixture oxides of the target metals, CuO and Cr₂O₃, as well as aluminium as reducing agent are used. Because the Sh-factor for the studied mixtures for a target of more than 50 wt.-% Cu in the metal phase is very high, lime is added to lower the Sh-factor. The most promising mixtures of the thermodynamic calculations are Cu25Cr and Cu15Cr. Besides of varying the chromium content in the target metal the stoichiometry is also varied. Since one of the targets of this work is to get an aluminium content as low as possible, it is tried to let all the aluminium react and get into the slag phase as Al₂O₃. As it is nearly impossible to mix a system good enough to guarantee 100 % reaction, the approach of this work is to add more oxides of the target metals than needed for a stoichiometric reaction. In this way a slight loss of CuO or Cr₂O₃ is taken into account to lower the aluminium content of the material. As the affinity of Cr to O is much higher than the affinity of Cu to O it can be assumed that Cr₂O₃ needs to be added hyperstoichiometric to reach the target composition in the target metal. The relation of Cu to Cr in the target metal by then is controlled via the Al content in the input mixture, assuming nearly all of the Al to react as there are more reaction partners (excess Cr₂O₃) than needed.

Altogether the following mixtures have been tried out:

Table 1: Input mixtures for ATR

Cu content /wt.-%	Cr content /wt.-%	Stoichiometry Cr ₂ O ₃
85	15	stoichiometric
85	15	hyperstoichiometric
75	25	hyperstoichiometric

The mixture with the best results regarding Al content, accuracy of the target metal and metal yield, Cu15Cr hyperstoichiometric, is scaled up to a larger scale of 115 kg input material. This is the size needed to produce VAR usable electrodes via inline casting later on.

3.2. Inline casting

With the scale up being successful the mould for inline casting is attached to the same reactor used at the scale up. Different types of moulds have been taken into account but finally a mould using the principle of uphill casting is used for casting the electrode. The final design of the reactor with attached mould can be seen on figure 2. On the left hand side of this figure the connection between reactor and mould can be seen.

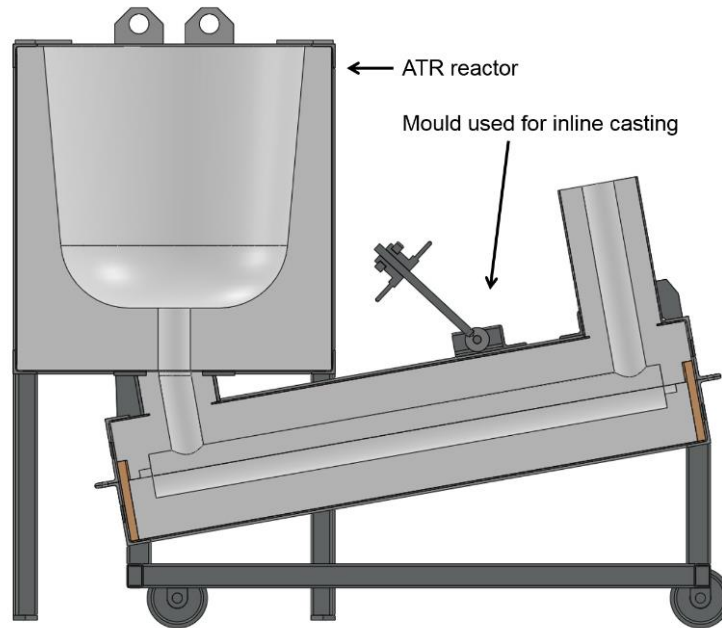

Figure 2: Schematic of the ATR reactor with attached mould

At the bottom of the reactor a small aluminium plate seals the connection to the mould to avoid the mixture of input material falling into the mould before the start of the reaction. After ignition the reaction front migrates through the mixture towards the bottom of the reactor. As soon as the reaction front reaches the aluminium plate the plate is melted by the energy of the reaction and the liquid material flows into the mould. On the other, higher side of the mould there is a hole to let reaction gases and also air stream out of the mould making way for the liquid metal.

3.3. Vacuum arc remelting

To refine the material the electrode produced via ATR and inline casting is remelted in a VAR. The electrode is attached to a stub as can be seen on figure 3 and then inserted into the VAR. The electrode without stub has a length of 520 mm, a diameter of 70 mm and a weight of 19.8 kg. The diameter of the mould is 120 mm.



Figure 3: Electrode with attached stub prepared for the VAR process

As there is no history of remelting Cu alloys, especially CuCr, at the IME, process parameters for the VAR such as melt rate/current and drip shorts/voltage can only be assumed and need to be adjusted and enhanced throughout the first remelting.

As copper has a very high thermal conductivity the remelting of CuCr is not as linear as of a standard VAR alloy such as Ni-based superalloys or Ti-based alloys. It takes much longer for the electrode to start moving as not only the bottom of the electrode is heated up but due to the high thermal conductivity the whole electrode is heated up before the electrode tip is hot enough to start melting.

4. Results

4.1. Aluminothermic reduction

The results of the preliminary trials demonstrate that higher Cu contents in the target phase and therefore in the system are leading to lower Al concentrations in the metal. Also a hyperstoichiometric addition of Cr_2O_3 decreases the Al content in the target metal. This can both be seen on figure 4.

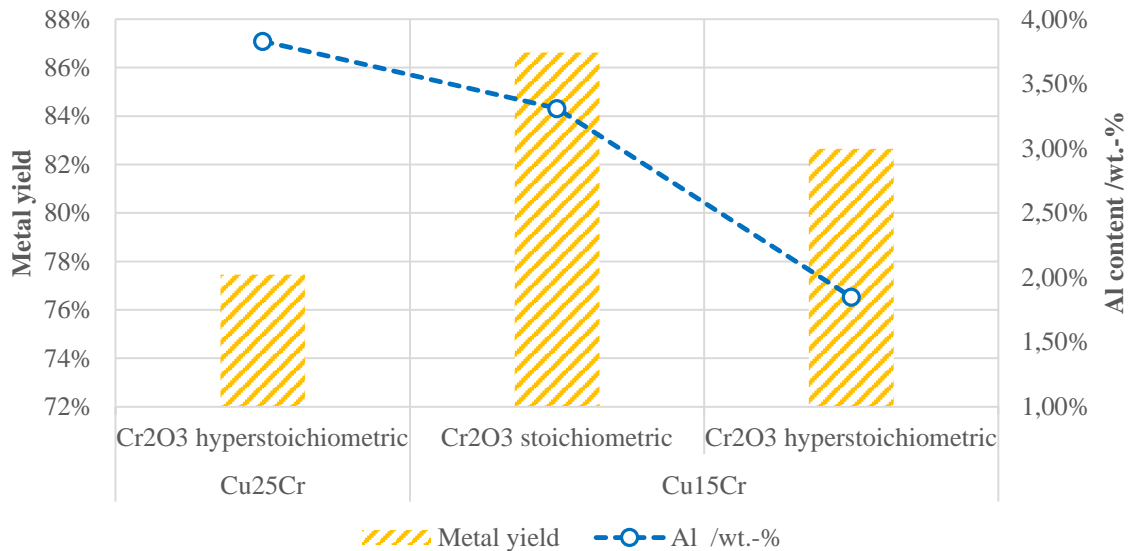

Figure 4: Al content and metal yield of preliminary trials

The metal yield of the trials with the higher Cu content (Cu15Cr) is also significantly higher. This can be explained by the lower affinity of copper to oxygen and therefore a more complete reduction of the target metal. It can also be seen that in order to get rid of aluminium in the target metal a certain metal loss is unavoidable as the trials with the lowest Al content do not have the best, but still a satisfactory, metal yield.

As the most promising mixture (Cu15Cr, hyperstoichiometric) is scaled up to 115 kg the Al content gets down to an even lower level. The final Al content of the electrode obtained by inline casting is 0.35 wt.-%, so it should be possible to get rid of nearly all of this during remelting in the VAR. The metal yield of the scale up trial also is higher than that of the preliminary trials.

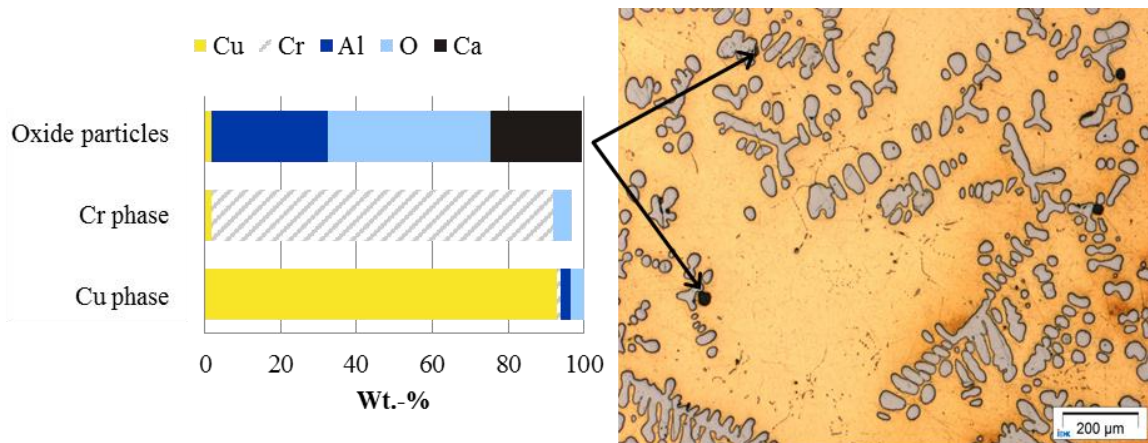

Figure 5: Micro of the microstructure of the scale up Cu15Cr trial with EDS analysis

Figure 5 shows that the Cr in the obtained metal block forms dendrites in the Cu matrix. So Cu and Cr are neither alloyed to one homogeneous alloy nor is the Cr spread in form of small randomly shaped droplets.

On figure 5 there are also black spots visible. EDS phase analysis shows that these spots are oxide particles that did not settle to the slag phase. These oxide particles mainly consist of Al, O and Ca. This reflects the slag composition of CaO and Al₂O₃. The oxide particles are always very close to the Cr dendrites. One explanation is that the solid Cr dendrites form before the slag particles can rise to the top of the melt and hold them down.

4.2. *Inline casting*

As to be seen on figure 6 after casting the mould did not fill completely but therefore the connection between mould and reactor was filled with metal. This was not intended but the electrode after machining is still remeltable in the VAR process. Therefore the ingot casting can be seen as a success although there is room for improvement.



Figure 6: Metal product of ATR inline casting (top) and electrode prepared for VAR (bottom)

4.3. *Vacuum arc remelting*

The product of the VAR remelting obtains no surface defects and has no shrinkage cavity. After the ingot has been cut in half there are grey spots visible that later on are identified as Cr. So a complete uniform distribution of Cr has not been achieved. But as can be seen at the SEM image on the right side of Figure 7 despite the few grey spots the rest of the Cr is spread in very small dendrites. A comparison of these dendrites with the dendrites formed after ATR shows that VAR leads to a much finer and, apart from the few grey spots, more uniform microstructure than ATR.

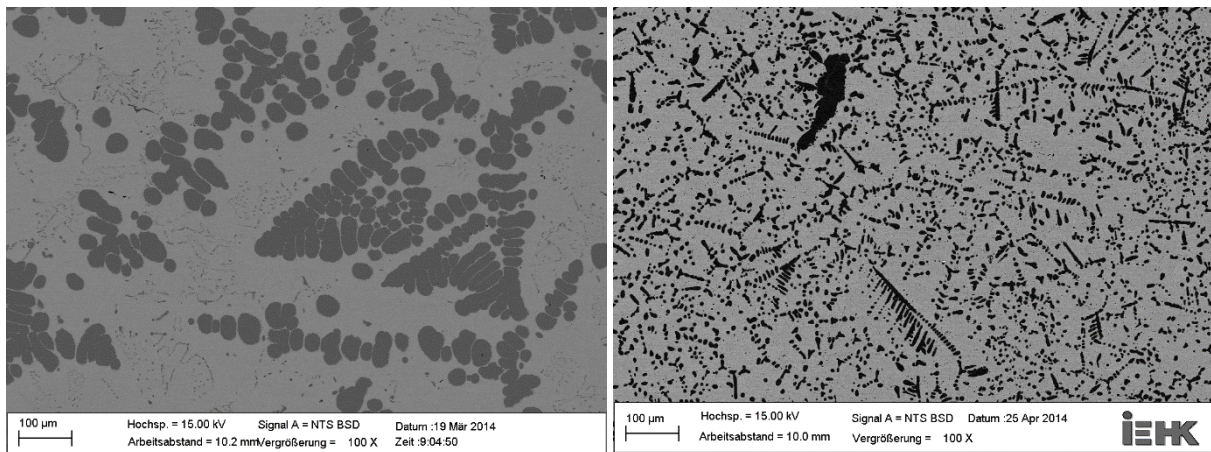

Figure 7: Comparison of the microstructure before (left) and after (right) VAR on SEM images

There is another unwanted effect besides the grey spots of pure Cr after the VAR remelting: There are strong macro segregations of the Cr throughout the Cu. So at the walls of the mould there is hardly any Cr to be found. As figure 8 shows this macro segregations lead to a very discrete separation between the Cu matrix with Cr and a nearly pure Cu phase.

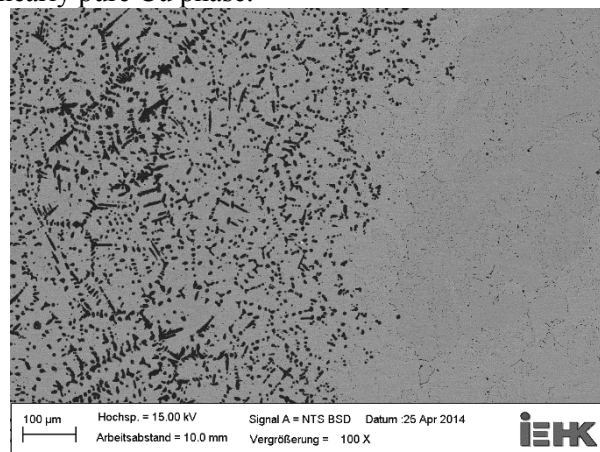

Figure 8: Visible Cr segregations on a SEM image

These segregations can be explained by the very high cooling rate in the VAR. As there is a massive cooling of the copper mould there is an enormous temperature gradient inside of the solidifying ingot. This temperature gradient leads to a segregation of the high melting Cr towards the warmer centre of the ingot.

The Al content of the ingot is below detection limit of a XRF. This means that it is possible to get rid of a certain amount of Al remaining from the ATR.

An approach on eliminating the segregations is using lower melting rates to generate a shallower melt pool and have faster cooling conditions. The next steps will be trying to reduce the melt rate down to the lowest tolerable limit to see what can be done to get rid of the segregations. Also a second VAR step and its effect on segregations will be tested

5. Conclusions

This investigation shows that it is possible to produce copper chromium alloys by using a combination of ATR and VAR. To obtain a product usable in medium voltage switches there must be a focus on the aluminium content and the homogeneity of the metal. Inline casting is of great help in obtaining a VAR

remeltable electrode directly from the ATR process. CuCr alloys are remeltable in a VAR furnace and it is possible to get rid of Al up to a certain limit. But further investigations on how to obtain a homogenous ingot without macro segregations need to be carried out.

References

- [1] D. Mayer, "Werkstoffe für die Mittelspannungsenergietechnik Kupfer-Chrom-Basis (Cu/Cr), Werkstoffinformation Firma Doduco, 2011
- [2] Zhou et al. "On the metastable miscibility gap in liquid Cu-Cr alloys" Journal of Materials Science 44, 2009, pp. 3793-3799 Another reference
- [3] K.T. Jacob, S. Priya, Y. Waseda, "A Thermodynamic Study of Liquid Cu-Cr Alloys and Metastable Liquid Immiscibility", Zeitschrift für Metallkunde, Vol. 91, 2000, pp. 594-600
- [4] D.J. Chakrabarti, D.E. Laughlin, "The Cr-Cu (Chromium-Copper) System", Bulletin of Alloy Phase Diagrams, Volume 5 No. 1, 1984, pp. 59-68
- [5] G. Gottstein, M. Winning, B. Friedrich, "Chemische Technik: Prozesse und Produkte"
- [6] W. Dautzenberg, "Untersuchung über die aluminothermische Gewinnung von Manganmetall, Ferrotitan und Chrommetall", RWTH Aachen, 1944
- [7] D.K. Melgaard, R.L. Williamson, J.J. Beaman, "Controlling Remelting Processes for Superalloys and Aerospace Ti alloys", Journal of the Minerals, Metals & Materials Society, 1998, pp 13-17
- [8] R.L. Boxman, P.J. Martin, D.M. Sanders, "Handbook of Vacuum Arc Science and Technology", Noyes Publications, 1995