

# Recycling of Titanium-Aluminide Scrap

B. Friedrich, J. Morscheiser, J. Reitz

RWTH Aachen University, IME Process Metallurgy and Metals Recycling, Intzestr. 3, 52056 Aachen, Germany

C. Lochbichler

formerly IME, now voestalpine Giesserei Traisen GmbH, Mariazellerstr. 75, A-3160 Traisen, Austria

Copyright © 2009 ITA

## ABSTRACT

This article presents the latest results in developing a closed loop recycling process for titanium-aluminide scrap, which is presently downgraded as a deoxidation agent in steel production. The IME process is an innovative combination of industrially approved processes like Vacuum Induction Melting (VIM) with Metallothermic Desoxidation, Pressure Electro Slag Remelting (PESR) and Vacuum Arc Remelting (VAR).

The paper will show, as a significant innovation for the titanium industry, the results of semi-pilot scale experiments at IME for the production of 200 mm diameter VIM-PESR-VAR-ingots from 100% scrap regarding process window definition and material characterisation. The presentation will close with a general benchmark comparison with primary TiAl-production.

## INTRODUCTION

Due to high scrap generation during the manufacturing of semi-finished and final products made from titanium and titanium alloys, recycling shows a great potential to substitute titanium sponge, economize the titanium market and to apply secondary low cost titanium in new applications.

Estimates are that starting from a 1.8 t titanium block made by VAR melting of titanium sponge, 1.0 t of semi-finished products are produced. Normally just about 0.4 t of end products can be yielded within further processing of the semi-finished products. In the worst case material yield is only about 10% of semi-finished products in case of complex mechanically produced final construction parts [1]. 60% of the processing scrap is downgraded by use in non structural applications (i.e. as alloying feed stock in steel and aluminium industry).

Due to high corrosion resistance and low density titanium aluminides show a great potential as material for structural applications in the aerospace and automotive industry. However the high material and production costs for semi-finished products actually slow down a break-through to mass production of  $\gamma$ -TiAl.

For titanium aluminides processing yields should be comparable to standard titanium alloys processed via the casting route. On the other hand  $\gamma$ -TiAl alloys are produced at a tremendously higher cost due to strict specifications on alloy composition and homogeneity.

Several research projects at IME, Aachen currently aim on cost reduced production methods for  $\gamma$ -TiAl and on the minimisation of downgrading  $\gamma$ -TiAl scrap. This paper summarizes these activities and completes the picture of a viable recycling route for titanium aluminides.

## MAIN SECTION

### CONCEPT

An alternative process for the production of titanium aluminides by aluminothermic reduction (ATR) and subsequent deoxidation via pressure electroslag remelting (PESR) has been already presented in [2][3][4]. The positive results in the deoxidation of these high-oxygen titanium aluminides with calcium have been transferred to an integrated concept for recycling of titanium aluminide scraps as presented in figure 1.

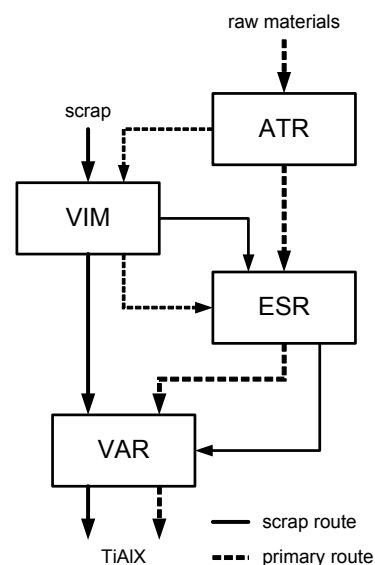

Figure 1: Integrated concept for alternative production and recycling of TiAl developed at IME, Aachen

In this concept, the preliminary melting of scrap is done by conventional VIM using specialized ceramic linings. This includes pre-deoxidization by metallothermic reaction with calcium metal. The second process step is final deoxidization by PESR using a continuously reactivated Ca-containing slag. Finally VAR removes small slag inclusions as well as dissolved Ca and allows for hydrogen degassing. For each step special equipment requirements and metallurgical challenges are inherent and lead to different refining opportunities.

### MELTING AND DEOXIDATION BY VIM

The titanium activity in Ti-Al-melts is significantly lower ( $a_{Ti} \sim 0,2-0,3$ ) compared to pure titanium melts and with  $\sim 1550^\circ\text{C}$ , the melting point is around  $100^\circ\text{C}$  lower compared to pure titanium. Because of these facts and in spite of the well-known chemical aggressiveness of titanium melts towards oxide crucibles, scrap melting can be conducted in conventional vacuum induction furnaces using oxide based refractories. This ensures economy due to strongly increased energy efficiency compared to a highly sophisticated titanium recycling metallurgy based on water-cooled copper moulds (CHEBM) or "cold crucibles" (Induction Skull Melting). The application of conventional VIM offers best chemical homogenisation due to inductive stirring, composition adjustment via hot sampling and alloy charging, excellent heat control and heat distribution due to direct heating by induced eddy currents, hence a controlled evaporation of volatile elements and finally a high flexibility regarding feed material (shape, dimension, number of scrap and primary materials).

In order to evaluate and control the chemical and thermal stability of different refractory linings and the corresponding oxygen pick-up during the melt, thermochemical modelling is applied. Target is the calculation of the thermochemical equilibrium (i.e. oxygen content of liquid metal phase) as a function of process temperature and crucible material. The procedure consists in searching the minimum of total Gibbs energy  $G_{tot}$  of the considered system and accordingly to the change in free Gibbs energy of reaction  $\Delta G^R = 0$  for equation (1) which represents the reaction of a TiAl melt with an oxide based refractory.



with:  $<Me_mO_n>$  - solid crucible material (e.g.  $Al_2O_3$ ),  
 (X) - liquid Ti or Ti/TiAl alloy,  $\delta$  - extent of reaction with  $\delta [0, \alpha]$

Figures 2 and 3 show the results of the thermochemical modelling based on data from Factsage® (Version 5.5) in case of unalloyed titanium respectively binary  $\gamma$ -TiAl (50 at.% Al) and pure alumina ( $Al_2O_3$ ) as crucible material. As can be observed in figure 2, there is no equilibrium reached within the considered extend of reaction. The total amount of alumina will be dissolved in titanium and the final oxygen content is only limited by the dissolved mass of oxide.

Therefore alumina crucibles are not suitable for melting pure titanium. In case of binary titanium aluminide however an equilibrium is reached because of the decreased titanium activity and the corresponding oxygen content of the melt should reach values between 0,5 and 1,15 wt.% in equilibrium depending on the temperature.

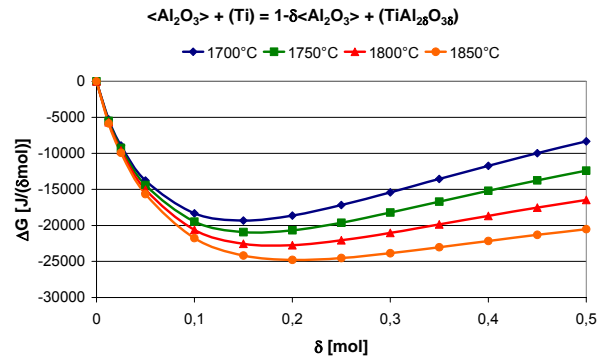

Figure 2:  $\Delta G_R = f(\delta, T)$  in case of liquid unalloyed titanium versus pure  $Al_2O_3$

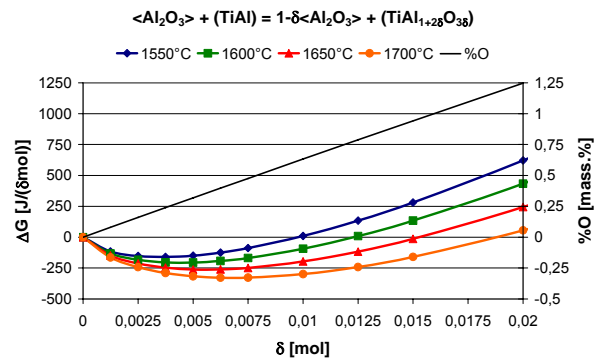

Figure 3:  $\Delta G_R = f(\delta, T)$  in case of liquid binary  $\gamma$ -TiAl (50 at.% Al) versus pure  $Al_2O_3$

Via experimental melts in a laboratory scale VIM furnace (200 g melts), the thermochemical modelling was validated and the stability of various commercial refractory crucibles was investigated and compared to the calculations. Lowest oxygen levels were achieved for yttria ( $Y_2O_3$ ) and calcia (CaO) crucibles in experiment and calculation. For  $\gamma$ -TiAl melts in a CaO crucible, equilibrium oxygen levels of 1900 to 3000 ppm were obtained in both lab-scale and pilot scale VIM (30 kg melts), which is a promising start for further refining and deoxidation in PESR.

Because of the unavoidable oxygen pick-up during melting, a so called direct deoxidisation can be employed in VIM to reduce oxygen content. This is realized by dipping a Ca-Al master alloy or alternatively yttrium metal directly into the melt. Calcium dissolves in the melt and precipitates CaO. Figure 4 is based on equilibrium trials of Tsukihashi et al. [5] and shows the expected solubility product between calcium and oxygen content in liquid TiAl,  $TiAl_3$  and Ti in contact with pure calcia, hence the activity of CaO is assumed to be unity.

It should be noted that  $\gamma$ -TiAl and Ti show virtually the same equilibrium constant  $K$ . However in the experiments of Tsukihashi Ti shows significantly lower Ca contents and hence higher oxygen contents than TiAl.

In the present examination on the melting of  $\gamma$ -TiAl alloys by VIM a deoxidisation below 500 ppm oxygen was achieved. Scrap from spent  $\gamma$ -TiAl sputter targets was charged into a VIM-furnace and molten under 800 mbar inert gas (argon) atmosphere. During deoxidation solid CaO was floated up and accrued at the crucible walls. By REM examination of the void are in the cast ingots, the formation of a calcia-alumina mixed oxide slag was also observed. While excess calcium evaporates, the homogeneous melt is quickly cast into a water-cooled copper mould (compare figure 5). Removal of non-metallic inclusions and final deoxidization shall then be served in a second processing step by PESR or VAR.

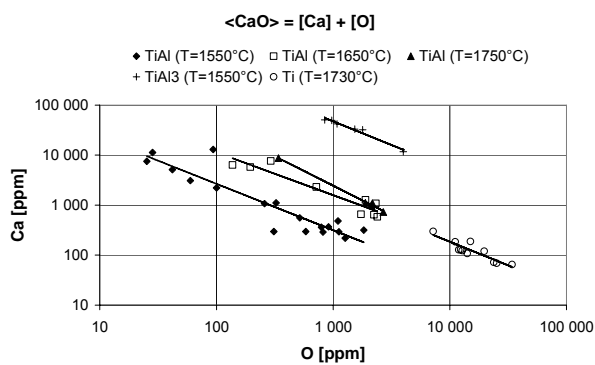

Figure 4: Dependency between Ca and O content in molten TiAl, TiAl<sub>3</sub> and Ti (based on data from [5])

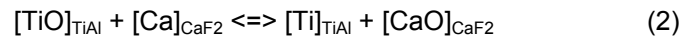

Figure 5: VIM-cast TiAl electrode ( $\varnothing$  105 mm, L 750 mm, mass approx. 25 kg)

## REFINING AND DEOXIDATION BY PESR

In ESR the tip of a consumable electrode is dipped into a molten flux. The flux is heated by AC current to the melting point of the metal and the electrode and melts continuously while the metal droplets travel through the slag due to the difference in density. Just like in VAR a liquid metal bath (here below the slag) collects the droplets and through solidification the process continuously builds up a refined ingot with a controlled microstructure and smooth surface.

A range of suitable fluxes for the electroslag remelting of titanium alloys have been investigated thoroughly by Nafziger [6] with the outcome that fluorspar (CaF<sub>2</sub>) offers the best combination of thermochemical stability, stable processing conditions and final ingot quality. Thermochemical calculations have shown that even the deoxidation of pure titanium should be possible by ESR using “reactive slags” where metallic calcium is added to the flux as a deoxidation agent. Again calcium is chosen as a reactant, because of its high oxygen affinity, good solubility in the slag and available activity data for the equilibrium of Ca and O in titanium melts. Dissolution of calcium from the slag into the metal phase results in the precipitation of CaO as applied in VIM, with the difference the precipitated CaO will be dissolved in the ESR slag and hence, because CaO activity is smaller than one, lower oxygen levels should be achievable with less calcium being dissolved in the metal. As a trade-off calcium activity in the slag is also reduced compared to direct deoxidation with calcium in VIM. A chemical reaction for the deoxidation of a titanium alloy by ESR is given in eq. (2).



In order to model this metal slag reaction and allow for a controlled deoxidation by ESR the activities of the slag components in the system CaF<sub>2</sub>-CaO-Ca have to be known. A calculation of the ternary system CaF<sub>2</sub>-Ca-CaO based on the available data from the binary systems was therefore conducted using the OptiSage-Module within FactSage™ V 5.5 and applying a sublattice type model according to the Kohler-Toop approach, assuming that there was neither a tendency for near range ordering (like in silica melts where a quasi-chemical model is usually applied) nor a tendency for alloying (like in metal melts, where the compound energy formalism holds in most cases). [3]

As a main characteristic of the ESR-process only a partial volume of the total metal is in the molten state during the process. To ensure an uniform oxygen content with respect to the full length of an ingot, the oxygen potential in the slag has to be carefully controlled during the whole melting process. Unfortunately, the slag enriches in CaO during the melt and is being depleted in calcium as deoxidation goes on. To compensate for this effect calcium activity has to be continuously increased during the process. Additionally the CaO-activity itself can be decreased by dilution through the addition of fresh CaF<sub>2</sub>. Based on the calculated activities, the chemical equilibrium between oxygen in the metal and oxygen in the slag can be expressed as the necessary concentration of Ca in the slag at a given CaO content. The result of this calculation is condensed in figure 6. It can be clearly expected that a desoxidation to lowest oxygen levels (< 100 ppm) can only be reached with extremely low CaO contents and high Ca concentrations, while the industrial target of 500 ppm oxygen should be possible throughout the full scale of CaO solubility of the slag by adjusting the Ca content according to figure 6.

Due to the current lack of reliable methods for online-measurement of these activities in the slag under the harsh remelting conditions, the calcium content of the slag has to be controlled using mass-balance calculations and continuous feeding of deoxidation agents, which was put into practice as a computer based spreadsheet. Because the calcium vapour-pressure in the slag is near one atmosphere, also calcium evaporation was to be included in this calculation.

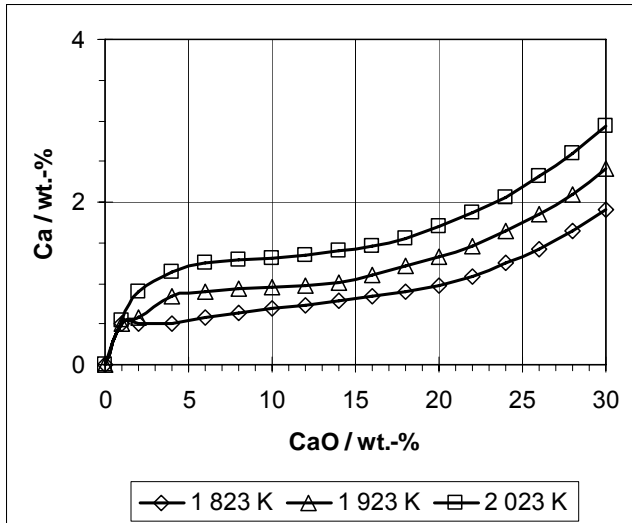

Figure 6: Necessary Ca content in the active slag in order to reach 480 ppm oxygen in a binary TiAl melt, depending on CaO-content of the slag.

As an experimental proof of the modelled principle, four melts were conducted on 100mm electrodes obtained by VIM from remelting spent  $\gamma$ -Ti50Al sputter targets as described above. In order to prevent excessive calcium evaporation and allow for better control of the experiment, melts were carried out at argon pressures of 10 and 20 bars in a pilot-scale pressure ESR (PESR) furnace (Leybold-Heraeus, now ALD) capable of operating under inert-gas overpressures up to 50 bar. This institute equipment is supplied by a 5 kA/66 V power control and latest monitoring and melt-control systems. The PESR crucible used is made from copper and has a conical shape of 178 mm diameter at the base-plate and 159 mm at its rim and measures 880 mm in height.

Feeding rates for Ca and  $\text{CaF}_2$  were varied with the aim to achieve the best possible deoxidation. Melts were carried out based on the best industrially available WACKER 2052 flux (> 97,5%  $\text{CaF}_2$ ) with initial CaO-content of the obtained batch determined to be 1,17% by a titration method. For starting the process, a pile of welded chunks from scrap material was used to allow for proper heating and melting of the solid slag. In order to control the slag composition, the charging of additional slag and calcium was conducted during the processing time using calibrated screw feeders. The exact amount charged was double-checked after the trial by mass-balance on the material leftover in the slag bunkers.

After melting the obtained ingots (d ~ 160 mm, h ~ 280 mm) were cleaned from the slag skin and wedges were cut in the top, middle and bottom section (figure 7) in order to evaluate chemical homogeneity and the efficiency of deoxidation. In the most successful trial oxygen contents from 450 (bottom) to 250 ppm (top sample) were measured by hot-gas extraction method with a Ströhlein-ON mat 8500 and confirmed by an external lab. Calcium content in the metal amounts between 800 and 1260 ppm as expected from theory.



Figure 7: Sampling of obtained, deoxidized PESR ingots

#### FINAL REFINING BY VAR

At the present stage of development in  $\gamma$ -TiAl technology it seems to be generally agreed that the sum of interstitial elements (N, C, O) in titanium aluminides in order to achieve desired mechanical properties for structural applications should be limited to 1000 ppm. The upper limit for oxygen in TiAl seems to be accepted in the range of < 800 ppm. In this sense  $\gamma$ -TiAl alloys have quality requirements largely twice as tough as for established Ti alloys presently applied like Ti6Al4V (Grade 5) with upper of oxygen < 2000 ppm.

In order to reach sufficient deoxidation in VIM the underlying experiments have shown that calcium contents in the range of 2000 ppm are found in the deoxidized cast bars. For equally efficient deoxidation in PESR experimental findings are that ~ 1000 ppm of calcium will be necessarily dissolved in the metal. In contrast to the established limits for interstitials the influence of calcium and fluorine on mechanical properties of TiAl is presently not known and no indications have been found in literature. In the presented recycling concept, vacuum arc remelting (VAR) is therefore applied for final refining of recycled  $\gamma$ -TiAl from either VIM or PESR, with special regard to the removal of excess Ca and H by evaporation or degassing.

Evaporation of Ca from TiAl in VAR can be thermochemically expected based on sufficiently high vapour pressure as indicated in figure 8.



Calculations for the expected evaporation rate were conducted based on the Langmuir equation for ideal evaporation conditions by taking into account that the evaporation rate will decrease with decreasing Ca contents, Ca activity and therefore decreasing Ca vapour pressure. For the experimental conditions in the pilot-scale VAR with an annulus gap of 50 mm between the 110 mm electrode and the 160 mm copper crucible a maximum evaporation rate of 1,2 g/s was estimated. A complete removal of Ca from e.g. 1 kg  $\gamma$ -TiAl50 (at%) starting from an initial concentration of 1500 ppm Ca should occur in 6,6 s, 50 ppm Ca should be obtained already after 3,9 s, while 100 ppm Ca should be reached after 3,1 s, 750 ppm Ca after 0,8 s and so forth. Because vapour pressure under experimental conditions lies in the thermochemically favourable range of  $10^{-2}$  mbar, only the melt-rate during VAR should be adopted accordingly to the desired final Ca content. In other words the melt rate for (nearly) complete removal of Ca should be below 10 kg/min for the experimental conditions given below.

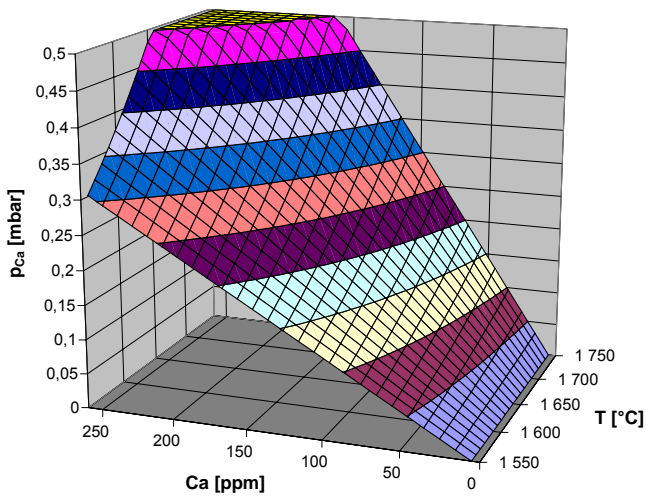

Figure 8: Vapour pressure calculation indicates that even at low super-heat ( $T=1550^{\circ}\text{C}$ ) removal of Ca lower than 40 ppm should be possible at 0,05 mbar process pressure.

For the equilibrium of hydrogen partial pressure in the atmosphere and hydrogen content in liquid the following relationship (3) could be obtained from literature [7] which is plotted in figure 8.

$$\log c = \frac{1}{2} \cdot \log p - 2,0 + \frac{2460}{T} \quad (3)$$

C - hydrogen concentration [at%], p – hydrogen partial pressure [Torr], T – temperature [K]

From a thermochemical perspective hydrogen removal should be successful given the fact that total pressures in the range of  $10^{-2}$  mbar are achieved and that furthermore the hydrogen partial pressure should only be a small fraction of that.

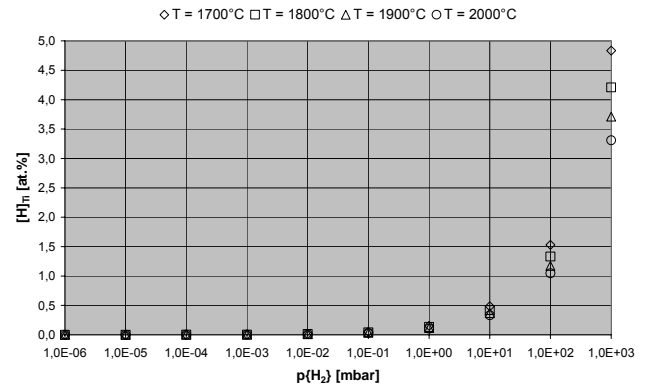

Figure 8: Hydrogen content in liquid titanium is depending on hydrogen partial pressure in the furnace atmosphere.

In order to evaluate these estimations for both calcium and hydrogen, several electrodes (diameter 110 mm, 800 mm long) from  $\gamma$ -Ti50Al were cast in VIM and deoxidized as described above. These electrodes were not remelted by PESR but directly fed into VAR. As explained above, deoxidation in VIM ends with higher calcium levels than the PESR treatment, in this sense a VIM cast electrode represents a tougher test for evaporation capabilities of the VAR process. During remelting in VAR in a 160 mm crucible at 24 V and 4 kA, a melt rate of 1,4 kg/min was obtained. The melt was carried out in a vacuum of  $<1 \cdot 10^{-3}$  mbar.

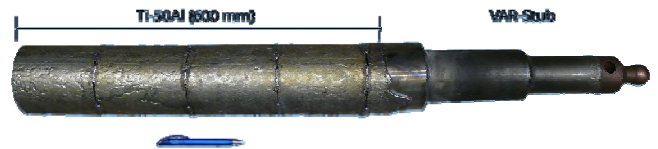

Figure 9: Sampled and welded VIM-cast electrode ready for final refining in VAR

Samples were taken from different positions in the electrode (figure 9) and on corresponding positions in the obtained ingot. The samples were examined by x-ray fluorescence (XFA) and hot-gas extraction for metallic elements and interstitials. It could be shown that concentration of Ca in all obtained samples were below the detection limit of XFA.

The samples were furthermore examined on Leica DM 2500M light microscope. In each sample three rectangular surfaces of  $1,2 \text{ mm}^2$  were randomly selected and observed at 100x magnification. Inclusions were observed in both the VIM cast and the VAR refined TiAl and automatically counted and measured with the analysIS Pro 3.2 software (Soft Imaging System GmbH). It can clearly be observed in figure 10 that the inclusion-density increases by melting and deoxidation in VIM but is afterwards reduced again due to refining in VAR. Differences between the original state and the VAR refined state are marginal and below the accuracy of the method to draw any further conclusions.

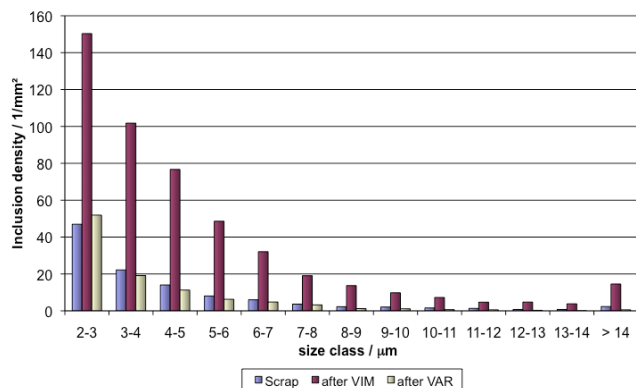

Figure 10: After VAR, inclusion content in the range 1-14 µm could be reduced to original level (spent sputter targets)

## CONCLUSION

Intensive research was carried out in order to develop and assess a recycling process for titanium aluminide alloys. The concept comprises melting and preliminary deoxidation in VIM, final deoxidation by PESR and further refining via VAR. After modelling the thermochemistry and partially also kinetics of these processes, trials were carried out in pilot scale using 110 mm electrodes with promising results concerning deoxidation and purity of the recycled material. The industrial targets of <800 ppm oxygen could be always guaranteed. Next steps will include the recycling of titanium aluminide alloys for structural applications and the behaviour of segregating elements, as well as the capabilities of the process chain to remove carbides.

## ACKNOWLEDGMENTS

The authors would like to acknowledge financial support of their research by the German Federal Ministry for education and research (BMBF) (contract No. 01RW0410) and the European Commission within the EU FP6 project IMPRESS (contract number NMP3-CT-2004-500635). The authors also acknowledge the

support of GfE Nürnberg, ACCESS e.V., ALD Vacuum Technologies and RHI Refractories giving constant technical assistance.

## REFERENCES

1. H. Sibum, Titan und Titanlegierungen, in: Manfred Peters und Christoph Leyens Wiley-VCH Verlag GmbH & Co.KGaA, Weinheim, p 245 ff, (2002).
2. Stoephasius, J.-C.; Friedrich, B.; Hammerschmidt, J.; A New Processing Route for Titanium Alloys by Aluminothermic Reduction of Titanium Dioxide and Refining by ESR, in: Ti-2003 Science and Technology, Proceedings of the 10th World Conference on Titanium, ed. G. Lütjering and J. Albrecht, Vol. IV, WILEY-VCH Verlag GmbH & Co. KGaA, Weinheim, 2004, ISBN 3-527-30306-5, pp. 2209-2216
3. Stoephasius, J.C., Reitz, J., Friedrich, B; "ESR Refining Potential for Titanium Alloys using a CaF<sub>2</sub>-based Active Slag", in: Advanced Engineering Materials 9, No. 4, 2007; DOI: 10.1002/adem.200700009
4. Stoephasius, J.C.; Friedrich, B., Production of γ-TiAl-Ingots by Aluminothermic Reduction of TiO<sub>2</sub> and Refining by ESR, in: Proceedings of EMC 2005, Dresden, 1429 – 1444
5. F. Tsukihashi, E. Tawara and T. Hatta, in: Metallurgical and Materials Transactions B, Volume 27B, 967-72 (1996)
6. R.H. Nafziger; Slag compositions for Titanium Electroslag Remelting and Effects of Selected Melting Parameters, in: Second International Symposium on Electroslag Remelting Technology, September 23-25 1969
7. Becker, H.; Zwicker, U.: IVa Metalle – Titan, in: Gase und Kohlenstoff in Metallen – Zweiter Teil: Daten, E. Fromm und E. Gebhardt (Eds.), Springer Verlag 1976, ISBN 3-540-07255-1, S. 397